

UL 1682

Plugs, Receptacles, and Cable
Connectors of the Pin and
Sleeve Type

*UL COPYRIGHTED MATERIAL –
NOT AUTHORIZED FOR FURTHER REPRODUCTION OR
DISTRIBUTION WITHOUT PERMISSION FROM UL*

Underwriters Laboratories Inc. (UL)
333 Pfingsten Road
Northbrook, IL 60062-2096

UL Standard for Safety for Plugs, Receptacles, and Cable Connectors of the Pin and Sleeve Type, UL 1682

Third Edition, Dated August 6, 2007

SUMMARY OF TOPICS

This new edition provides the updated ANSI recognition of the Standard for Plugs, Receptacles, and Cable Connectors of the Pin and Sleeve Type, UL 1682.

The new and/or revised requirements are substantially in accordance with UL's Proposal(s) on this subject dated October 13, 2006.

As indicated on the title page (page 1), this UL Standard for Safety is an American National Standard. Attention is directed to the note on the title page of this Standard outlining the procedures to be followed to retain the approved text of this ANSI/UL Standard.

The UL Foreword is no longer located within the UL Standard. For information concerning the use and application of the requirements contained in this Standard, the current version of the UL Foreword is located on ULStandardsInfoNet at: <http://ulstandardsinfo.net/ulforeword.html>

The master for this Standard at UL's Northbrook Office is the official document insofar as it relates to a UL service and the compliance of a product with respect to the requirements for that product and service, or if there are questions regarding the accuracy of this Standard.

UL's Standards for Safety are copyrighted by UL. Neither a printed copy of a Standard, nor the distribution diskette for a Standard-on-Diskette and the file for the Standard on the distribution diskette should be altered in any way. All of UL's Standards and all copyrights, ownerships, and rights regarding those Standards shall remain the sole and exclusive property of UL.

All rights reserved. No part of this publication may be reproduced, stored in a retrieval system, or transmitted in any form by any means, electronic, mechanical photocopying, recording, or otherwise without prior permission of UL.

Revisions of UL Standards for Safety are issued from time to time. A UL Standard for Safety is current only if it incorporates the most recently adopted revisions.

UL provides this Standard "as is" without warranty of any kind, either expressed or implied, including but not limited to, the implied warranties of merchantability or fitness for any purpose.

In no event will UL be liable for any special, incidental, consequential, indirect or similar damages, including loss of profits, lost savings, loss of data, or any other damages arising out of the use of or the inability to use this Standard, even if UL or an authorized UL representative has been advised of the possibility of such damage. In no event shall UL's liability for any damage ever exceed the price paid for this Standard, regardless of the form of the claim.

***UL COPYRIGHTED MATERIAL –
NOT AUTHORIZED FOR FURTHER REPRODUCTION OR
DISTRIBUTION WITHOUT PERMISSION FROM UL***

UL will attempt to answer support requests concerning electronic versions of its Standards. However, this support service is offered on a reasonable efforts basis only, and UL may not be able to resolve every support request. UL supports the electronic versions of its Standards only if they are used under the conditions and operating systems for which it is intended. UL's support policies may change from time-to-time without notification.

UL reserves the right to change the format, presentation, file types and formats, delivery methods and formats, and the like of both its printed and electronic Standards without prior notice.

Purchasers of the electronic versions of UL's Standards for Safety agree to defend, indemnify, and hold UL harmless from and against any loss, expense, liability, damage, claim, or judgement (including reasonable attorney's fees) resulting from any error or deviation introduced while purchaser is storing an electronic Standard on the purchaser's computer system.

If a single-user version electronic Standard was purchased, one copy of this Standard may be stored on the hard disk of a single personal computer, or on a single LAN file-server or the permanent storage device of a multiple-user computer in such a manner that this Standard may only be accessed by one user at a time and for which there is no possibility of multiple concurrent access.

If a multiple-user version electronic Standard was purchased, one copy of the Standard may be stored on a single LAN file-server, or on the permanent storage device of a multiple-user computer, or on an Intranet server. The number of concurrent users shall not exceed the number of users authorized.

Electronic Standards are intended for on-line use, such as for viewing the requirements of a Standard, conducting a word search, and the like. Only one copy of the Standard may be printed from each single-user version of an electronic Standard. Only one copy of the Standard may be printed for each authorized user of a multiple-user version of an electronic Standard. Because of differences in the computer/software/printer setup used by UL and those of electronic Standards purchasers, the printed copy obtained by a purchaser may not look exactly like the on-line screen view or the printed Standard.

An employee of an organization purchasing a UL Standard can make a copy of the page or pages being viewed for their own fair and/or practical internal use.

The requirements in this Standard are now in effect, except for those paragraphs, sections, tables, figures, and/or other elements of the Standard having future effective dates as indicated in the preface. The prior text for requirements that have been revised and that have a future effective date are located after the Standard, and are preceded by a "SUPERSEDED REQUIREMENTS" notice.

New product submittals made prior to a specified future effective date will be judged under all of the requirements in this Standard including those requirements with a specified future effective date, unless the applicant specifically requests that the product be judged under the current requirements. However, if the applicant elects this option, it should be noted that compliance with all the requirements in this Standard will be required as a condition of continued Listing, Recognition, and Follow-Up Services after the effective date, and understanding of this should be signified in writing.

Copyright © 2007 Underwriters Laboratories Inc.

***UL COPYRIGHTED MATERIAL –
NOT AUTHORIZED FOR FURTHER REPRODUCTION OR
DISTRIBUTION WITHOUT PERMISSION FROM UL***

This Standard consists of pages dated as shown in the following checklist:

Page	Date
1-68	August 6, 2007
A1-A4	August 6, 2007
B1-B4	August 6, 2007

No Text on This Page

***UL COPYRIGHTED MATERIAL –
NOT AUTHORIZED FOR FURTHER REPRODUCTION OR
DISTRIBUTION WITHOUT PERMISSION FROM UL***



Canadian Standards Association
CSA C22.2 No. 182.1-07
Third Edition



Underwriters Laboratories Inc.
UL 1682
Third Edition

Plugs, Receptacles, and Cable Connectors of the Pin and Sleeve Type

August 6, 2007



ANSI/UL 1682-2007

*UL COPYRIGHTED MATERIAL –
NOT AUTHORIZED FOR FURTHER REPRODUCTION OR
DISTRIBUTION WITHOUT PERMISSION FROM UL*

Commitment for Amendments

This standard is issued jointly by the Canadian Standards Association (CSA), and Underwriters Laboratories Inc. (UL). Comments or proposals for revisions on any part of the standard may be submitted to CSA or UL at any time. Revisions to this standard will be made only after processing according to the standards development procedures of CSA and UL. CSA and UL will issue revisions to this standard by means of a new edition or revised or additional pages bearing their date of issue.

ISBN 978-1-55436-514-2

© 2007

Canadian Standards Association

All rights reserved. No part of this publication may be reproduced in any form whatsoever without the prior permission of the publisher.

To purchase CSA Standards and related publications, visit CSA's Online Store at www.ShopCSA.ca or call toll-free 1-800-463-6727 or 416-747-4044.

Copyright © 2007 Underwriters Laboratories Inc.

Revisions of this Standard will be made by issuing revised or additional pages bearing their date of issue. A UL Standard is current only if it incorporates the most recently adopted revisions, all of which are itemized on the transmittal notice that accompanies the latest set of revised requirements. Comments or proposals for revisions on any part of the Standard may be submitted to UL at any time. Proposals should be submitted via a Proposal Request in UL's On-Line Collaborative Standards Development System (CSDS) at <http://csds.ul.com>.

The most recent designation of ANSI/UL 1682 as an American National Standard (ANSI) occurred on August 15, 2007.

This ANSI/UL Standard for Safety, which consists of the Third edition is under continuous maintenance, whereby each revision is ANSI approved upon publication.

To purchase UL Standards, visit COMM 2000 at http://www.comm-2000.com/help/how_to_order.aspx or call toll-free 1-888-853-3503.

***UL COPYRIGHTED MATERIAL –
NOT AUTHORIZED FOR FURTHER REPRODUCTION OR
DISTRIBUTION WITHOUT PERMISSION FROM UL***

CONTENTS

Preface	5
1 Scope	7
2 Definitions	7
3 General	9
3.1 Components	9
3.2 Reference publications	10
3.3 Units of measurement	13
4 Construction	13
4.1 General	13
4.2 Configurations	13
4.3 Insulating material	13
4.4 Resistance to corrosion	15
4.5 Enclosures	15
4.6 Current-carrying parts	16
4.7 Clearances and creepage distances	17
4.8 Accessibility of live parts	18
4.9 Grounding (bonding) and dead-metal parts	18
4.10 Grounding (bonding) connections	20
4.11 Terminal parts	20
4.12 Assembly	21
4.13 Interlocks	22
4.14 Devices intended to accommodate a fuse	22
4.15 Cord or cable grip	23
5 Tests	24
5.1 Representative devices	24
5.2 Accelerated aging	24
5.3 Comparative tracking index	25
5.4 Glow wire	25
5.5 High-current arc resistance to ignition	25
5.6 Mold stress relief	26
5.7 Moisture absorption resistance	27
5.8 Humidity	28
5.9 Insulation resistance	28
5.10 Dielectric withstand	29
5.11 Conductor secureness	29
5.12 Cord or cable secureness	30
5.13 Impact (plugs and connectors)	30
5.14 Crush	31
5.15 Withdrawal force	32
5.16 Grounding (bonding) path current	32
5.17 Short circuit withstand (motor rated devices)	33
5.18 Strength of insulating base and support	39
5.19 No-load endurance	40
5.20 Endurance with load	40
5.21 Overload	41
5.22 Abnormal overload	42
5.23 Horsepower rated locked rotor	43
5.24 Electromagnetic (pilot contacts)	43
5.25 Temperature rise	44

5.26 Resistance to arcing	44
5.27 Polarization integrity	45
5.28 Resistance to corrosion	45
5.29 Moisture resistance	45
5.30 Environmental enclosure type designators	46
6 Ratings	46
6.1 General	46
7 Markings	47
7.1 Details	47
7.2 Identification and marking of terminals	53

ANNEX A

Component Standards

ANNEX B

Mandatory English and French Markings for Canada

Preface

This is the common UL and CSA Standard for plugs, receptacles, and cable connectors of the pin and sleeve type. It is the third edition of CSA C22.2 No. 182.1 and the third edition of UL 1682. This edition of CSA C22.2 No. 182.1 supersedes the previous editions, published in 2002 and 1988.

This common Standard was prepared by the Canadian Standards Association (CSA) and Underwriters Laboratories Inc. (UL).

This Standard is considered suitable for use for conformity assessment within the stated scope of the Standard.

This Standard was reviewed by the CSA Subcommittee on C22.2 No. 182.1 under the jurisdiction of the CSA Technical Committee on Wiring Products and the CSA Strategic Steering Committee on Requirements for Electrical Safety, and has been formally approved by the CSA Technical Committee.

This Standard has been approved by the American National Standards Institute (ANSI) as an American National Standard.

A UL standard is current only if it incorporates the most recently adopted revisions, all of which are itemized on the transmittal notice that accompanies the latest set of revised requirements.

Where reference is made to a specific number of samples to be tested, the specified number is considered a minimum quantity.

Note: *Although the intended primary application of this Standard is stated in its Scope, it is important to note that it remains the responsibility of the users of the Standard to judge its suitability for their particular purpose.*

Level of harmonization

This Standard is published as an equivalent Standard. An equivalent Standard is a Standard that is substantially the same in technical content, except as follows. Technical deviations are allowed for Codes and Government Regulations and those recognized as being in accordance with NAFTA Article 905, for example, because of fundamental, climatic, geographical, technological, or infrastructural factors, scientific justification, or the level of protection that the country considers appropriate. Presentation is word for word except for editorial changes.

Interpretations

The interpretation by the SDO of an identical or equivalent Standard is based on the literal text to determine compliance with the Standard in accordance with the procedural rules of the SDO. If more than one interpretation of the literal text has been identified, a revision is to be proposed as soon as possible to each of the SDOs to more accurately reflect the intent.

CSA Effective Date

The effective date for CSA International will be announced through *CSA Informs* or a CSA certification notice.

**UL COPYRIGHTED MATERIAL –
NOT AUTHORIZED FOR FURTHER REPRODUCTION OR
DISTRIBUTION WITHOUT PERMISSION FROM UL**

UL Effective Date

As of August 6, 2007, all products Listed, Recognized, or Classified by UL must comply with the requirements in this Standard.

***UL COPYRIGHTED MATERIAL –
NOT AUTHORIZED FOR FURTHER REPRODUCTION OR
DISTRIBUTION WITHOUT PERMISSION FROM UL***

1 Scope

1.1 This standard applies to pin and sleeve type plugs, receptacles, power inlets, and connectors, rated up to 800 amperes and up to 600 volts ac or dc, and which may include two or fewer pilot contacts. These devices are intended to provide power from branch circuits, or are for direct connection to the branch circuit in accordance with the Canadian Electrical Code Part I (CEC), C22.1, and the National Electrical Code (NEC), ANSI/NFPA 70, using copper conductors, for use in either indoor or outdoor nonhazardous locations. In Canada, the terminals of a device intended to accommodate aluminum conductors also comply with CSA C22.2 No. 65, Wire Connectors.

1.2 In the U.S. this standard does not apply to single conductor pin and sleeve devices.

1.3 This standard does not apply to:

- a) Devices molded integrally with flexible cord or cable that are covered by the Standard for Cord Sets and Power Supply Cords, UL 817 and Cord Sets and Power Supply Cords, CSA C22.2 No. 21;
- b) General and special use devices, such as attachment plugs, receptacles, cord connectors, inlets, current taps, flatiron and appliance plugs, that are covered by the Standard for Attachment Plugs and Receptacles, UL 498 and General Use Receptacles, Attachment Plugs, and Similar Wiring Devices, CSA C22.2 No. 42, Appliance Plugs for Heater Cord Sets, CSA C22.2 No. 57, and Industrial Locking Type, Special Use Attachment Plugs, Receptacles, and Connectors, CSA C22.2 No. 182.2;
- c) Single and multi-pole connectors, which may include 3 or more pilot contacts, intended for connection to copper conductors, for use in data, signal, control and power applications within and between electrical equipment, where exposed, that are covered by the Standard for Component Connectors for Use in Data, Signal, Control and Power Applications, UL 1977 and Special Use Attachment Plugs, Receptacles, and Connectors, CSA C22.2 No. 182.3;
- d) Devices intended for use in hazardous (Classified) locations that are covered by the Standard for Receptacle-Plug Combinations For Use in Hazardous (Classified) Locations, UL 1010 and Attachment Plugs, Receptacles, and Similar Wiring Devices for Use in Hazardous Locations: Class I, A, B, C, and D, Class II, Group G in Coal or Coke Dust, and in Gaseous Mines, CSA C22.2 No. 159;
- e) Products such as switched interlocks that are covered by the Standard for Industrial Control Equipment, UL 508 and Industrial Control Equipment, CSA C22.2 No. 14;

2 Definitions

2.1 For the purposes of this standard, the following definitions apply.

2.2 CONNECTOR (CABLE CONNECTOR) – A portable receptacle that is intended to provide power, with means for attachment of flexible cord or cable and not intended for permanent mounting.

2.3 CONTACT – A conductive element in a component that mates with a corresponding element to provide an electrical path.

2.4 CONTACT, PILOT – A conductive element intended to carry an indicating or controlling signal.

**UL COPYRIGHTED MATERIAL –
NOT AUTHORIZED FOR FURTHER REPRODUCTION OR
DISTRIBUTION WITHOUT PERMISSION FROM UL**

2.5 DELAYED ACTION – An arrangement that delays the separation of device housings which is intended to reduce the likelihood of exposure of arcing contacts during the breaking of the circuit when the plug is withdrawn.

2.6 ENCLOSURE – The case or housing into which the insulator and contacts are assembled. The enclosure system may be composed of elements such as outlet boxes, mounting panels, receptacles, plugs, and connectors.

2.7 GROUNDING (BONDING) PATH – A path between the grounding pin, or contact and the grounding terminal or, if the device has no grounding terminal, the point at which the path makes contact with a part of the metal raceway system, such as a box, box cover, or the raceway itself.

2.8 GROUNDING TYPE DEVICE – A device having a grounding (bonding) path.

2.9 INSULATION, ELECTRICAL – The insulation necessary for the proper functioning of the product and for basic protection against electrical shock.

2.10 INSULATOR – That portion of a device that provides for separation and support of contacts.

2.11 INTERLOCKED RECEPTACLE (OUTLET) – An outlet having a device, either electrical or mechanical, that is intended to reduce the likelihood of energizing the contacts before proper engagement with the plug, and that either is intended to reduce the risk of the plug being withdrawn while its contacts are energized or deenergizes the line contacts before separation.

2.12 LOCKING RETAINING MEANS – A mechanical arrangement that holds a plug or connector in position when it is in proper engagement and is intended to reduce the likelihood of its unintentional withdrawal. It may also facilitate environmental sealing.

2.13 MOTOR RATING – A rating expressed in horsepower (hp) and/or full load locked-rotor current and voltage assigned to a device that is intended to control a motor load.

2.14 PIN AND SLEEVE DEVICE – A plug, receptacle, power inlet or connector utilizing contacts that generally are cylindrical or circular and telescoping and are shrouded by an extension of the enclosure of the mating devices.

2.15 PLUG (ATTACHMENT PLUG) – A device intended to receive power when inserted in a receptacle or connector, which establishes connection between conductors of the attached flexible cord or cable and the conductors connected to the receptacle or cable connector.

2.16 POWER INLET – A permanently mounted plug intended to receive power from a cable connector.

2.17 RECEPTACLE (OUTLET) – A device that is intended to provide power to an inserted plug, and that is installed as a fixed outlet or on equipment.

2.18 SWITCHED RECEPTACLE – An outlet with an associated or integral switching device to disconnect the supply from the receptacle contacts.

2.19 TERMINAL – A conductive part provided on a contact for connecting a conductor.

2.20 TERMINAL, CRIMP TYPE – A terminal in which an electro-mechanical connection is made between the terminal lug and a conductor by compressing the lug onto the conductors.

2.21 TERMINAL, FIELD WIRING – A terminal to which power supply, load, control, or equipment grounding connections will be made in the field when the device is installed.

2.22 TERMINAL, PRESSURE-WIRE – A terminal in which the conductor is clamped under a pressure plate or saddle by one or more screws or nuts.

2.23 TERMINAL, SET SCREW – A terminal in which the clamping pressure is applied by the end of the screw bearing directly on the conductor.

2.24 TERMINAL, WIRE-BINDING SCREW – A terminal in which the conductor is bent around the screw and is clamped directly under the head of the screw when it is tightened.

3 General

3.1 Components

3.1.1 Except as indicated in Clause 3.1.2, a component of a product covered by this standard shall comply with the requirements for that component. See Annex A for a list of standards covering components generally used in the products covered by this standard. A component shall comply with the Canadian Standards Association or the Underwriters Laboratories Inc. standards as appropriate for the country where the product is to be used.

3.1.2 A component is not required to comply with a specific requirement that:

- a) Involves a feature or characteristic not required in the application of the component in the product covered by this standard, or
- b) Is superseded by a requirement in this standard.

3.1.3 A component shall be used in accordance with its rating established for the intended conditions of use.

3.1.4 Specific components are incomplete in construction features or restricted in performance capabilities. Such components are intended for use only under limited conditions, such as certain temperatures not exceeding specified limits, and shall be used only under those specific conditions.

3.2 Reference publications

3.2.0 Products covered by this standard shall comply with the reference installation codes and standards as appropriate for the country where the product is to be used. When the product is intended for use in more than one country, the product shall comply with the installation codes and standards for all countries where it is intended to be used.

3.2.1 For undated references to standards, such reference shall be considered to refer to the latest edition and all revisions to that edition up to the time when this standard was approved. For dated references to standards, such reference shall be considered to refer to the dated edition and all revisions published to that edition up to the time the standard was approved.

CSA Standards

C22.1-06,
Canadian Electrical Code, Part I

CAN/CSA-C22.2 No. 0-M91 (R2006),
General Requirements – Canadian Electrical Code, Part II

C22.2 No. 0.2-93 (R2004),
Insulation Coordination

C22.2 No. 0.4-04,
Bonding of Electrical Equipment

C22.2 No. 0.15-01,
Adhesive Labels

CAN/CSA-C22.2 No. 0.17-00 (R2004),
Evaluation of Properties of Polymeric Materials

C22.2 No. 4-04,
Enclosed and Dead-Front Switches

CAN/CSA-C22.2 No. 5-02,
Molded-Case Circuit Breakers, Molded-Case Switches and Circuit-Breaker Enclosures

C22.2 No. 14-05,
Industrial Control Equipment

C22.2 No. 21-95 (R2004),
Cord Sets and Power Supply Cords

C22.2 No. 39-M1987 (R2003),
Fuseholder Assemblies

C22.2 No. 42-99 (R2004),
General Use Receptacles, Attachment Plugs, and Similar Wiring Devices

C22.2 No. 57-M1985 (R2005),
Appliance Plugs for Heater Cord Sets

**UL COPYRIGHTED MATERIAL –
NOT AUTHORIZED FOR FURTHER REPRODUCTION OR
DISTRIBUTION WITHOUT PERMISSION FROM UL**

C22.2 No. 65-03,
Wire Connectors

CAN/CSA-C22.2 No. 94-M91 (R2006),
Special Purpose Enclosures

C22.2 No. 111-00 (R2005),
General-Use Snap Switches

C22.2 No. 159-M1987 (R2004),
Attachment Plugs, Receptacles, and Similar Wiring Devices for Use in Hazardous Locations, Class I, Groups A, B, C, and D; Class II, Group G, in Coal or Coke Dust, and in Gaseous Mines

C22.2 No. 182.2-M1987 (R2004),
Industrial Locking Type, Special Use Attachment Plugs, Receptacles and Connectors

C22.2 No. 182.3-M1987 (R2004),
Special Use Attachment Plugs, Receptacles and Connectors

UL Standards

UL 20
General-Use Snap Switches

UL 50
Enclosures for Electrical Equipment

UL 94
Tests for Flammability of Plastic Materials for Parts in Devices and Appliances

UL 98
Enclosed and Dead-Front Switches

UL 486E
Equipment Wiring Terminals for Use with Aluminum and/or Copper Conductors

UL 489
Molded-Case Circuit Breakers, Molded-Case Switches, and Circuit-Breaker Enclosures

UL 498
Attachment Plugs and Receptacles

UL 508
Industrial Control Equipment

UL 512
Fuseholders

UL 746A
Polymeric Materials – Short Term Property Evaluations

UL 746B
Polymeric Materials – Long Term Property Evaluations

UL 746C
Polymeric Materials – Use in Electrical Equipment Evaluations

UL 817
Cord Sets and Power-Supply Cords

UL 840
Insulation Coordination Including Clearances and Creepage Distances for Electrical Equipment

UL 969
Marking and Labeling Systems

UL 1010
Receptacle-Plugs Combinations For Use In Hazardous (Classified) Locations

UL 1686
Pin and Sleeve Configurations

UL 1977
Component Connectors for Use in Data, Signal, Control and Power Applications

ANSI¹ Standards

ANSI/NFPA 70-2005²
National Electrical Code

ANSI/IEEE C37.09-1999 (2005)³
Test Procedure for AC High-Voltage Circuit Breakers Rated on a Symmetrical Current Basis

ASTM⁴ Standards

ASTM D 570-98 (2005)
Standard Test Method for Water Absorption of Plastics

ASTM E 28-99 (2004)
Standard Test Methods for Softening Point of Resins Derived from Naval Stores by Ring-and-Ball Apparatus

IEC⁵ Standards

IEC 60664-1 (2002-06)
Insulation Coordination for Equipment within Low-Voltage Systems Part 1: Principles, Requirements and Tests

IEC 60695-2-10
Fire Hazard Testing – Part 2-10: Glowing/Hot-Wire Based Test Methods – Glow-Wire Apparatus and Common Test Procedure

¹ American National Standards Institute.

² National Fire Protection Association.

³ Institute of Electrical and Electronics Engineers, Inc.

⁴ American Society for Testing and Materials.

⁵ International Electrotechnical Commission.

3.3 Units of measurement

3.3.1 Values stated without parentheses are the requirement. Values in parentheses are explanatory or approximate information.

4 Construction

4.1 General

4.1.1 The ratings mentioned throughout this standard, including those mentioned in Clause 6.1.2, represent the maximum ampacity and voltage for a device. A device is considered to be for use with either alternating or direct current unless the rating includes a marking to restrict the use to alternating current. See Clause 7.1.6.1.

4.2 Configurations

4.2.1 Combinations of pin and sleeve attachment plugs and receptacles are covered by this standard. Standardized configurations of attachment plugs and receptacle combinations are located in UL 1686.

4.3 Insulating material

4.3.1 A base or body in or on which live parts are mounted shall be of ceramic or other insulating material meeting the requirements of this standard.

4.3.2 Vulcanized fiber or rubber may be used for insulating washers, separators, and barriers, but not as the sole support for live parts. The material shall be moisture resistant in accordance with Clause 5.7.

4.3.3 A polymeric material used for electrical insulation, an internal barrier necessary to maintain electrical clearances and creepage distances, or enclosure of live parts shall have a flame class rating of HB, V-2, V-1, V-0, VTM-2, VTM-1, VTM-0, 5VA or 5VB in accordance with the requirements of UL 94 or CAN/CSA-C22.2 No. 0.17. The flammability classification shall be judged at the actual minimum thickness employed within 0.8 mm (1/32 inch) of live parts within the device.

4.3.4 In Canada, insulating materials in contact with current-carrying parts of devices that are intended for permanent installation shall have a minimum flammability classification of V-2 in accordance with CAN/CSA-C22.2 No. 0.17, in a thickness of 1.6 mm or in the minimum thickness in contact with that current-carrying part, whichever thickness is greater.

4.3.5 In Canada, insulating materials in contact with current-carrying parts of devices not intended for permanent installation shall have a minimum flammability classification of HB in accordance with CAN/CSA-C22.2 No. 0.17.

4.3.6 In Canada, as an alternative to the requirements of Clause 4.3.4, a thermosetting material may be used as an insulating material in contact with current-carrying parts of devices intended for permanent installation, provided that such material has the characteristics specified in (a) and (b) below:

a) A minimum flammability classification of HB in accordance with CAN/CSA-C22.2 No. 0.17; and

b) The continuous use temperature index (mechanical without impact) is a minimum of 100°C, in accordance with CAN/CSA-C22.2 No. 0.17.

4.3.7 The internal insulating systems of components for which component requirements exist need not have a flame class rating.

4.3.8 A small part meeting all the following criteria need not have a flame class rating:

a) Its volume does not exceed 2 cm³ (0.122 cubic inch);

b) Its maximum dimension does not exceed 3 cm (1.18 inches); and

c) Its location is such that it cannot propagate flame from one area to another or act as a bridge between a possible source of ignition and other ignitable parts.

4.3.9 Fiber and similar material that is equal to or less than 0.25 mm (0.010 inch) thick need not have a flame class rating.

4.3.10 A polymeric material used for electrical insulation, an internal barrier necessary to maintain electrical clearances and creepage distances, or enclosure of live parts shall comply with the requirements in Clauses 5.3 – 5.10.

4.3.11 A polymeric material having a maximum comparative tracking index (CTI) performance level class of 3 or a minimum CTI value of 175 need not comply with Clause 5.3.

4.3.12 A polymeric material having hot wire ignition (HWI) corresponding to the values shown in Table 1 for the applicable flammability classification need not comply with Clause 5.4.

4.3.13 A polymeric material having high-current arc resistance to ignition (HAI) corresponding to the values shown in Table 1 for the applicable flammability classification need not comply with Clause 5.5.

4.3.14 The internal insulating systems of components for which component requirements exist need not comply with the requirement in Clauses 5.3 – 5.5.

4.3.15 A small part meeting all the following criteria need not comply with the requirements in Clauses 5.3 – 5.5:

a) Its volume does not exceed 2 cm³ (0.122 cubic inch);

b) Its maximum dimension does not exceed 3 cm (1.18 inches); and

c) Its location is such that it cannot propagate flame from one area to another or act as a bridge between a possible source of ignition and other ignitable parts.

4.3.16 Fiber and similar material that is equal to or less than 0.25 mm (0.010 inch) thick need not comply with the requirements in Clauses 5.3 – 5.5.

4.3.17 A polymeric material used for electrical insulation, an internal barrier necessary to maintain electrical clearances and creepage distances, or enclosure of live parts shall have the temperature index ratings shown in Table 2 for the specific application of the insulating material.

4.4 Resistance to corrosion

4.4.1 Parts of iron or steel other than stainless steel parts shall be protected against corrosion, in accordance with Clause 5.28.

4.5 Enclosures

4.5.1 General

4.5.1.1 An enclosure shall be constructed to reduce the risk of unintentional contact with uninsulated live parts, as indicated in Clause 4.8.1, and to provide internal parts with protection from specified external conditions. Additional items used to form an enclosure, such as adapters, hoods, covers, and the like, shall be permitted to be permanently secured to the device. In Canada, elements of metallic enclosure systems such as outlet boxes and mounting panels shall be provided with a grounding terminal.

4.5.2 Mechanical Strength

4.5.2.1 An enclosure shall have adequate strength and rigidity in accordance with Clauses 5.13 and 5.14.

4.5.3 Nonmetallic enclosures

4.5.3.1 A nonmetallic enclosure or a nonmetallic part of an enclosure shall comply with the applicable requirements in UL 746C or CAN/CSA-C22.2 No. 94 for Special Purpose Enclosures.

4.5.3.2 If a nonmetallic enclosure is identified as being intended to be exposed to specific chemicals, oils, acids, solvents, cleaning agents, and the like, the performance of the enclosure material shall not be adversely affected by such substances as determined by applicable tests as described in UL 746A or CAN/CSA-C22.2 No. 0.17.

4.5.3.3 Pliable, molded natural or synthetic rubber, or a combination thereof, or a pliable composition, the basic constituent of which is vinyl chloride or a copolymer of vinyl chloride and vinyl acetate, in the finished device that complies with Clause 5.2, may be employed as an insulating material for the enclosure of an attachment plug or a cord connector.

4.5.4 Metallic enclosures

4.5.4.1 An enclosure may be constructed of iron, steel, copper, brass, zinc, aluminum, or their alloys. Aluminum alloys containing less than 80% aluminum shall not be used. Magnesium and its alloys shall not be used.

4.5.4.2 Zinc or a zinc-based alloy shall not be used for an enclosure or parts of an enclosure which are in the primary grounding path.

4.5.5 Attachment plugs

4.5.5.1 An attachment plug shall not be provided with more than one multiconductor cord-outlet hole.

4.5.6 Specific enclosures

4.5.6.1 An enclosure marked with one or more environmental enclosure type designations shall comply with the applicable requirements in Clauses 5.29 and 7.1.14.

4.6 Current-carrying parts

4.6.1 A current-carrying part shall be of silver, copper, a copper alloy, or other material acceptable for the application. Plated iron or steel shall not be used for parts that are depended upon to carry current.

4.6.2 Stainless steel may be employed for a part not subject to arcing.

4.6.3 Pressure wire terminal screws and wire binding screws shall be permitted to be made of plated iron or steel.

4.6.4 Iron or steel, if protected against corrosion by zinc, tin, or equivalent plating, may be used for screws, plates, yokes, or other parts that are employed as a means of clamping the conductor, provided that such parts are not the primary current-carrying members.

4.6.5 Suitable means shall be provided for retaining live parts within such limits of alignment as to ensure that plugs will enter receptacles, connectors, and the like in the intended manner.

4.6.6 Uninsulated live parts shall be secured in place to ensure the clearances and creepage distances required in Clauses 4.7.1 and 4.7.3 are maintained.

4.6.7 A current-carrying part shall be prevented from turning relative to the surface on which it is mounted if such turning would result in a reduction of spacings below the minimum acceptable values.

4.7 Clearances and creepage distances

4.7.1 The clearances and creepage distances shall be not less than 6.4 mm (1/4 inch) between:

- a) Field wiring terminals of opposite polarity; and
- b) A field wiring terminal and any other uninsulated metal part of a different polarity.

4.7.2 For field wiring terminals intended for solder connections using solid or tin dipped stranded wire only, the minimum clearances and creepage distances between the terminals shall be as specified in UL 840 or CSA C22.2 No. 0.2. See Clause 7.1.12.2.

4.7.3 In all circuits other than at field wiring terminals, the acceptability of the clearances and creepage distances between an uninsulated live part and any other uninsulated metal part, not of the same polarity shall be as specified in UL 840, IEC 60664-1, or CSA C22.2 No. 0.2.

4.7.4 The dead metal mentioned in Clause 4.7.3 includes a metal surface on which the device is mounted in the intended manner. A dead-metal screw head, rivet, or the like is not considered to be exposed to contact by persons after the device is installed in the intended manner, if it cannot be contacted by the probe illustrated in Figure 1.

4.7.5 Clearances and creepage distances shall be measured in accordance with UL 840, IEC 60664-1, or CSA C22.2 No. 0.2. In determining the pollution degree and overvoltage category, the end-use application may be considered for a higher pollution degree and may modify those characteristics given in Clauses 4.7.8 and 4.7.9.

4.7.6 Clearances and creepage distances shall be measured in all conditions of use, both with and without mating devices of the intended configuration installed and any movable parts displaced to the position of a minimum spacing.

4.7.7 The clearances and creepage distances required in Clause 4.7.1 shall be measured through air and over insulating and conductive surfaces with the device wired as intended with the maximum anticipated conductor size. They shall be measured from any point on the terminal that may contact the clamped conductor as in the case of a wire-binding-screw terminal, or from any point on the perimeter of an opening to receive a conductor in the case of an enclosed terminal.

4.7.8 Indoor use equipment shall comply with the requirements for pollution degree 3. Outdoor use equipment shall comply with the requirements for pollution degree 4, unless protection is afforded by a suitable enclosure appropriate for the installation in which case a lower pollution degree can be achieved. The interior of equipment with enclosure Types 3, 3S, 4, 4X, 6 and 6P or Marine Type shall comply with the requirements for pollution degree 3. Hermetically sealed or encapsulated enclosures shall comply with the requirements for pollution degree 1.

4.7.9 Plugs, connectors, inlets, and other cord connected devices shall be rated overvoltage Category II and receptacles and other devices connected to fixed wiring shall be rated overvoltage Category III as defined in UL 840, IEC 60664-1, or CSA C22.2 No. 0.2.

4.8 Accessibility of live parts

4.8.1 To reduce the likelihood of unintentional contact that may involve a risk of electric shock from uninsulated live parts, a live part shall not be contacted by the probe illustrated in Figure 1. See Clause 4.8.6.

4.8.2 The contacts of an outlet device need not be evaluated for accessibility.

4.8.3 The probe illustrated in Figure 1 shall be applied to any depth that the recessing will permit, and shall be rotated, changed in configuration or angled before, during, and after application to any position that is necessary to examine the device.

4.8.4 The probe mentioned in Clause 4.8.1 shall be used as a measuring instrument to judge the accessibility provided by the recessing and not as an instrument to judge the strength of a material. The probe shall be applied with a force of 13 N (3 lbf) to determine accessibility.

4.8.5 During the examination of a product to determine whether it complies with the requirements in Clause 4.8.1, the device shall be wired and assembled in accordance with the manufacturer's instructions. Any other part that may be opened or removed by the user without using a tool shall be opened or removed.

4.8.6 Mating devices shall not have exposed live contacts when fully mated or during engagement or withdrawal.

4.8.7 Compliance with Clause 4.8.6 shall be determined with the use of the probe shown in Figure 1 in every possible position. See Clause 4.8.3.

4.8.8 The probe shall not be applied to holes in the shroud provided for locking if they do not exceed 10.2 mm (0.400 inch) diameter.

4.9 Grounding (bonding) and dead-metal parts

4.9.1 A grounding type device shall have a separate contact for interconnection of the equipment grounding conductor. In Canada, the means for providing grounding and bonding shall comply with CSA C22.2 No. 0.4.

4.9.2 The equipment grounding terminal or lead and its corresponding contact of a male inlet or equipment outlet intended for permanent installation shall be conductively connected to the mounting means, housing, hood, shell or other dead-metal parts of a device that may come into contact with the equipment enclosure.

4.9.3 In the United States, the conductive connection need not be provided if the mounting means, housing, hood, or shell is constructed of an insulating material and the lack of ground continuity to the equipment enclosure is readily apparent.

4.9.4 In the United States, the conductive connection need not be provided if the device is marked in accordance with Clause 7.1.3.1.

4.9.5 A device that has a metal shell used as the grounding contact member shall be as follows:

- a) The surface of the shell that is depended upon for grounding continuity shall not have a non-conductive coating or otherwise be subjected to conditions that may result in loss of grounding continuity;
- b) One or more separate spring type components shall be incorporated to provide grounding path continuity;
- c) The grounding components shall be protected against damage; and
- d) In the United States, the shell shall comply with the requirements of Clause 5.16.

4.9.6 The grounding contact shall be located and formed so the path of electrical continuity to the grounding contact of the mating plug is completed before continuity is established between any other contact and its respective contact on the plug.

4.9.7 The grounding contact need not make contact before any other contact if the device is of the interlocked type, which requires disconnection of the supply circuit before the plug can be inserted or removed.

4.9.8 The grounding contact path, except for the metal housing or mounting, shall be of copper or a copper alloy or equivalent material. If a metal housing is a part of the primary equipment grounding path, it shall not be of zinc or a zinc-based alloy.

4.9.9 A copper-base alloy rivet, which is used to hold parts together in the grounding-contact path or forms a part of the grounding path, shall not contain less than 80 percent copper.

4.9.10 A connection in the grounding-contact path shall be secured by riveting, bolting, clamping, or welding or by an equivalent mechanical means of securement, capable of complying with the requirements of Clause 5.16.

4.9.11 In mating devices provided with an equipment-grounding contact, the grounding contact shall not be capable of touching a line-side phase contact, independent of any polarization feature of the enclosure. The above requirement is applicable only to devices rated 100 A and less, with four or fewer power contacts, excluding grounding contacts. Such devices shall comply with the requirements of Clause 5.26.

4.9.12 All exposed non-current-carrying metal parts of a device that are likely to become energized shall be conductively connected to the equipment ground.

4.9.13 Grounding and other dead-metal parts shall be secured in place so that the spacing required in Clause 4.7 are maintained.

4.10 Grounding (bonding) connections

4.10.1 The grounding (or bonding) conductors of a device shall not be smaller in size than as indicated in Table 3.

4.10.2 An integral grounding or bonding pigtail lead for field connection shall not be shorter than 150 mm (6 inches).

4.10.3 A terminal provided for the field connection of a grounding (or bonding) conductor shall:

- a) Employ a mechanical clamping means that does not depend upon solder for the connection of the wire; and
- b) Be capable of securing a conductor of the minimum size indicated in Table 3.

4.11 Terminal parts

4.11.1 Devices shall be provided with suitable terminals or leads for the connection of conductors having an ampacity not less than the current rating for which they are intended in accordance with NFPA 70 or CEC C22.1, as applicable. See Clauses 7.1.1.2 – 7.1.1.4.

4.11.2 In the United States, pressure wire and set screw terminals used with single or multiple copper conductors for fixed wiring shall comply with the applicable requirements in UL 486E. In Canada, the terminals of a device intended to accommodate 8 AWG or larger conductor shall comply with the requirements of CSA C22.2 No. 65.

4.11.3 The tightening torque for the field wiring terminals of the devices mentioned in Clause 4.11.2 shall be specified by the device manufacturer and shall be marked as described in Clause 7.1.12.1.

4.11.4 A terminal plate that has a tapped hole for a soldering lug or pressure-wire connector shall be at least 1.27 mm (0.050 inch) thick and shall have no fewer than two full threads in the metal for a terminal screw.

4.11.5 Wiring terminals of a receptacle or power inlet shall be located or protected such that they cannot be forced against the wiring in the terminal box or compartment during installation.

4.11.6 Crimp type terminals may be provided with an inspection hole at the end of the crimp well to assure the full insertion of the conductor. Devices with crimp terminals shall be provided with manufacturer's installation instructions and be used with stranded conductors only and marked in accordance with Clause 7.1.12.3.

4.11.7 Wire binding screws used in making electrical connections shall not be smaller than indicated in Table 4. Wiring terminal screws shall have no fewer than two threads of engagement into metal.

4.11.8 A No. 8 or larger binding screw that has more than the number of threads per inch indicated in Table 4, with a terminal plate formed from stock 0.76 mm (0.030 inch) thick, is not prohibited from having the metal extruded at the tapped hole to provide the two full threads of minimum engagement for the binding screw. To determine compliance with note b of Table 4, six devices shall be used. Solid 14 AWG (2.1 mm²) copper wire shall be placed under the screw head and wrapped 2/3 – 3/4 turn around the screw. The screw shall then be tightened with a clutch-type torque screwdriver which has been calibrated and preset to release at 1.8 N·m (16 lbf in).

4.11.9 A wiring terminal that involves a wire-binding screw shall have upturned lugs, or the equivalent, to hold a wire under the head of the screw.

4.11.10 Terminal parts that are depended upon to carry current and that come into contact with branch circuit conductors other than the grounding conductor, shall not have a coating of zinc or cadmium.

4.11.11 For a receptacle or an inlet, the integral supply leads shall not be shorter than 10 cm (4 inches).

4.12 Assembly

4.12.1 General

4.12.1.1 A device incorporating two or more pieces shall be of such design that any intended grounding contact polarization will not be defeated by improper assembly during installation.

4.12.1.2 Means shall be provided for securely attaching the body of an inlet to the supporting base. When assembled, the body shall be prevented from turning with respect to the base.

4.12.1.3 Screws upon which the permanent assembly of a device depends shall not loosen under normal use.

4.12.1.4 A device shall be capable of being readily wired as intended and shall be capable of accepting a flexible cord or cable having an ampacity at least equal to the rating of the device and of the type and size specified by the manufacturer.

4.12.1.5 Electrical contact shall be reliably maintained at any point at which a connection is made between current-carrying parts.

4.12.1.6 A sealing compound, if used, and in contact with live parts, shall be of an insulating, waterproof material that will not melt or flow at a temperature lower than the temperature rating of the conductors.

4.12.1.7 A determination of the softening point of a sealing compound shall be made in accordance with ASTM E 28.

4.12.1.8 Sulphur shall not be not acceptable as a sealing compound.

4.12.2 Mating and intermateability

4.12.2.1 A device, including any configuration illustrated in Figures C1 – C5 of UL 1686, shall be constructed so that electrical continuity between respective and similarly marked terminals is established when the mating plug and outlet device are connected together.

4.12.2.2 An outlet device shall not permit an attachment plug other than one that is specifically intended for use with the outlet to be inserted to the extent that electrical contact is made.

4.12.2.3 Attachment plugs, cord connectors, power inlets, receptacles, and other devices that have different electrical ratings or are intended to be wired with conductors having different temperature ratings shall not be interchangeable with one another. See Clauses 5.24.2, 7.1.1.3, and 7.1.1.4.

4.13 Interlocks

4.13.1 An interlocked switch or circuit breaker employed in an outlet-plug combination shall be constructed so the plug cannot be withdrawn from the outlet while the contacts are alive, or be inserted when the switch or circuit breaker is in the “On” position.

4.13.2 The interlocked switch or circuit breaker shall break all ungrounded supply conductors.

4.13.3 The interlocking mechanism shall comply with the requirements of Clause 5.19.

4.13.4 A pilot contact switch shall comply with the applicable requirements for auxiliary devices in UL 508 or CSA C22.2 No. 14.

4.13.5 A switch shall comply with the applicable requirements in UL 98 or CSA C22.2 No. 4, or UL 508 or CSA C22.2 No. 14, or UL 20 or CSA C22.2 No. 111.

4.13.6 An interlock employing a circuit breaker shall comply with the applicable requirements in UL 489 or CAN/CSA-C22.2 No. 5.

4.14 Devices intended to accommodate a fuse

4.14.1 Devices shall be constructed so that they will accommodate an enclosed fuse or fuses having a voltage rating not less than the voltage rating of the device.

4.14.2 The arrangement for holding the fuse shall comply with the requirements in UL 512 or CSA C22.2 No. 39.

4.14.3 A device shall include provision for a fuse in each ungrounded conductor, but there shall not be any provision for a fuse in any other conductor.

4.14.4 The removal or replacement of a fuse shall not expose any live parts in a device to personal contact.

4.14.5 The construction of a plug shall ensure that a fuse or fuses will not be removable when the plug is engaged in an outlet.

4.14.6 An enclosure shall be provided for the fuse or fuses in a device intended to accommodate such components. An enclosure shall comply with all of the following:

- a) It shall be of a moisture-resistant material in accordance with Clause 5.7.
 - 1) Fiber and similar absorptive materials shall not be considered as having moisture-absorptive properties acceptable for use as the enclosure of a fuse.
 - 2) Molded phenolic and similar thermosetting polymeric materials shall be considered as having moisture-absorptive properties acceptable for use as the enclosure of a fuse.
- b) It shall reduce the likelihood of persons unintentionally contacting uninsulated live parts of the fuse and fuse holder.
- c) It shall confine the effects of a fuse rupture to the interior of the enclosure.
- d) It shall comply with the requirements for insulating materials in Clauses 4.3.3 – 4.3.5.

4.14.7 Polymeric materials used as the enclosure of a fuse shall have a flame class rating of V-0, V-1, V-2, 5VA, or 5VB in accordance with the requirements of UL 94 or CAN/CSA-C22.2 No. 0.17.

4.15 Cord or cable grip

4.15.1 A cord or cable grip shall be provided on a plug or cord connector to:

- a) Permit the flexible supply cord or cable to be readily replaced; and
- b) Prevent a stress to be transmitted to the conductor connections within the terminal enclosure.

4.15.2 Devices provided with a suitable flexible conduit adapter or threaded inlet need not comply with the requirement of Clause 4.15.1.

4.15.3 If the cord or cable grip is threaded to the enclosure, it shall form a tight engagement. When assembled in the intended manner, the cord or cable entry shall not turn or loosen. The grip and cord or cable entry shall be smooth and free from sharp edges that may damage the jacket of the flexible cord or cable.

4.15.4 The strain relief means shall be capable of being easily tightened or assembled on the specified flexible cords to grip both the jacket and individually insulated conductors so that forces exerted on the cord (pushing or pulling) are not transmitted to the wiring terminal.

4.15.5 The cord or cable grip shall comply with the requirements of Clause 5.12.

5 Tests

5.1 Representative devices

5.1.1 Prior to initial electrical testing all devices shall be assembled or installed in accordance with the manufacturer's instructions. Testing with the use of a 60 Hz supply voltage may represent testing with the use of a higher frequency supply voltage not exceeding 400 Hz. A 60 Hz test current at 110 percent of the rated current is considered to represent a 50 Hz rating.

5.1.2 Unless stated otherwise, the test potential of a test circuit shall not be less than the test potential in volts corresponding to the voltage rating of devices as indicated in Table 5.

5.1.3 Unless indicated for use at a higher ambient temperature, the tests shall be conducted at any ambient temperature within the range of 10 – 40°C (50 – 104°F). The ambient temperature shall be determined using either thermometers or thermocouples placed in the vicinity of the equipment being tested. See Clause 7.1.1.1.

5.1.4 Temperature readings shall be obtained by means of thermocouples consisting of 28 – 32 AWG (0.08 – 0.032 mm²) iron and constantan wires. It is a common practice to employ thermocouples consisting of 30 AWG (0.05 mm²) iron and constantan wires with a potentiometer type of indicating instrument. This equipment shall be used if a referee measurement of temperature is necessary.

5.1.5 Unless stated otherwise, three representative devices shall be used for each test. A lesser number of complete devices may be used if:

- a) The test can be repeated using different portions of a previously tested device; and
- b) Agreeable to all parties concerned.

5.1.6 Devices shall be subjected to the appropriate tests outlined in Table 6.

5.2 Accelerated aging

5.2.1 Rubber compounds

5.2.1.1 A molded-rubber attachment plug, or cord connector, or parts shall not show any apparent deterioration and no greater change in hardness than five numbers as the result of exposure for 70 hours in a full-draft circulating-air oven at a temperature of 100.0 ±1.0°C (212.0 ±1.8°F).

5.2.1.2 If possible, the molded rubber device shall be used complete. The hardness of the rubber shall be determined as the average of five readings with an appropriate gauge, such as the Rex hardness gauge or the Shore durometer. The device shall be allowed to rest at room temperature for four or more hours after removal from the oven. The hardness shall be determined again as the average of five readings. The difference between the average original hardness reading and the average reading taken after exposure to the heat conditioning is the change in hardness.

5.2.1.3 The accelerated-aging tests mentioned in Clauses 5.2.1.1 – 5.2.1.2 shall be made on each color of rubber and on each basic rubber compound employed for the device.

5.2.2 PVC compounds

5.2.2.1 A device having a body of molded plasticized polyvinyl chloride or a polyvinyl chloride copolymer thermoplastic elastomer having a hardness of Shore D65 or less shall not show any cracks, discoloration, or other visible signs of deterioration as the result of exposure for 96 hours in a full-draft circulating-air oven at a temperature of $100.0 \pm 1.0^{\circ}\text{C}$ ($212.0 \pm 1.8^{\circ}\text{F}$).

5.3 Comparative tracking index

5.3.1 A polymeric material used for electrical insulation, an internal barrier necessary to maintain electrical clearances and creepage distances, or enclosure of live parts, tested in accordance with UL 746A or CAN/CSA-C22.2 No. 0.17, shall have a minimum Performance Level Class of 3 or a minimum CTI voltage of 175.

5.4 Glow wire

5.4.1 A polymeric material used for electrical insulation, an internal barrier necessary to maintain electrical clearances and creepage distances, or enclosure of live parts shall be tested in accordance with the requirements of Clause 5.4.2 to determine its resistance to ignition from overheated conductors caused by circuit overloads.

5.4.2 Three finished devices, or fewer, if appropriate, shall be subjected to the glow wire ignition test described in UL 746C or IEC 60695-2-10. There shall not be ignition of the insulating material during 30 seconds of application of the probe at $750^{\circ}\text{C} \pm 10^{\circ}\text{C}$.

5.5 High-current arc resistance to ignition

5.5.1 A polymeric material used for electrical insulation, an internal barrier necessary to maintain electrical clearances and creepage distances, or enclosure of live parts, when tested as described in Clauses 5.5.4 – 5.5.7 shall not ignite within the number of arcs specified in Table 7 for the flame class of the insulating material. In addition, there shall not be dielectric breakdown caused by formation of a permanent carbon conductor path.

5.5.2 An insulating material used in the face of an outlet device that has been subjected to the test in Clause 5.25 need not be subjected to the test in Clause 5.5.1.

5.5.3 An insulating material that has previously been accepted for use in the face of an outlet device in accordance with Clause 5.5.2 shall be acceptable for use in other applications without being subjected to the test in Clause 5.5.1.

5.5.4 Three fully assembled devices shall be tested. When preparing devices for test, the condition that will cause the greatest arcing near the material being tested in the device shall be simulated. For example, if the material being tested is used in the face of an attachment plug, one line contact shall be connected to the test circuit described in Clause 5.5.5.

5.5.5 The test circuit shall provide test currents and test voltages equal to the current and voltage ratings of the device to be tested but not exceeding 30 A or 240 V ac in any case. The test arc shall be established between the live parts and any adjacent part where breakdown is likely to occur. The arc shall be used to attempt to ignite materials forming parts of the enclosure or to ignite materials located between the parts of different potential. The arc shall be established by means of a copper or stainless steel conductive probe. The conductive probe shall be used to break through insulation, create arc tracking or create a carbon build-up across the surface of the insulating material at the rate of 30 – 40 arc separations per minute. The arc length developed with the probe shall not exceed the creepage distances specified in UL 840 or CSA C22.2 No. 0.2.

5.5.6 Immediately following the completion of the arcing portion of the test, the device shall be subjected to a 50 – 60 Hz essentially sinusoidal potential applied as described in Clause 5.5.7 between live parts of opposite polarity and between live parts and non-current carrying parts. The test potential shall be as indicated in Clause 5.10. Humidity conditioning shall not be applied.

5.5.7 The device shall be tested by means of a 500 VA or larger capacity transformer whose output voltage is essentially sinusoidal and can be varied. The applied potential shall be increased from zero until the required test level is reached, and shall be held at that level for one minute. The increase in the applied potential shall be at a uniform rate and as rapid as is consistent with its value being correctly indicated by a voltmeter.

5.5.8 If the output of the test-equipment transformer is less than 500 volt-amperes, the equipment shall include a voltmeter in the output circuit to indicate the test potential directly.

5.6 Mold stress relief

5.6.1 As a result of temperature conditioning specified in Clause 5.6.3, there shall not be any warpage, shrinkage, or other distortion that results in any of the following:

- a) Making uninsulated live parts, other than exposed wiring terminals, or internal wiring accessible to contact, by the probe illustrated in Figure 1. See Clause 4.8.3;
- b) Defeating the integrity of the enclosure so that acceptable mechanical protection is not afforded to the internal parts of the device;
- c) Interference with the operation, function or installation of the device;
- d) A condition that results in the device not complying with the strain relief requirements, if applicable;
- e) A reduction of clearances and creepage distances between uninsulated live parts of opposite polarity, uninsulated live parts, and accessible dead or grounded metal below the minimum acceptable values; and
- f) Any other evidence of damage that could increase the risk of fire or electric shock.

5.6.2 Devices employing only thermosetting materials need not be subjected to the mold stress relief test.

5.6.3 The devices shall be placed in a circulating-air oven maintained at a temperature of at least 10°C (18°F) higher than the maximum temperature of the device measured during the temperature test described in Clause 5.24, but not less than 70°C (158°F). The devices shall remain in the oven for 7 hours, then be removed from the oven and allowed to cool to room temperature before determining compliance.

5.6.4 Immediately following the completion of this test, the devices shall be subjected to the test described in Clause 5.10.

5.7 Moisture absorption resistance

5.7.1 Moisture-resistant insulating materials shall not absorb more than 6% of water by mass.

5.7.2 The material shall be:

- a) Dried at 105 ±5°C for 1 hour;
- b) Weighed (W_1);
- c) Immersed in distilled water at 23 ±1°C for 24 hours;
- d) Removed from the distilled water and the excess surface moisture wiped off; and
- e) Reweighed (W_2).

5.7.3 The moisture absorbed by the material shall be calculated as:

$$\frac{W_2 - W_1}{W_1} \times 100\%$$

5.7.4 A material tested in accordance with ASTM D 570 and having a value of 6% or less need not be tested.

5.8 Humidity

5.8.1 Devices shall not be adversely affected by humid conditions which may occur in anticipated use.

5.8.2 Cable entries, if any, shall be left open. If knock-outs are provided, one of them shall be opened.

5.8.3 Previously untested devices wired as intended, shall be used for this test. A mating attachment plug shall be inserted into the contact openings of one of the mating devices. Covers which can be removed without the aid of a tool shall be removed and subjected to the humidity conditioning with the main part; spring lids shall be open during this conditioning.

5.8.4 The devices shall be placed for 7 days (168 hours) into an environmental chamber maintained at a minimum relative humidity of $90 \pm 2\%$, and at a temperature (t) of $35 \pm 2^\circ\text{C}$ ($95 \pm 3.6^\circ\text{F}$).

5.8.5 After this conditioning, the devices shall be subjected to the tests described in Clauses 5.9 and 5.10.

5.9 Insulation resistance

5.9.1 In the United States, the insulation resistance of a device, after conditioning as indicated in Clause 5.8, shall not be less than 5 megohms.

5.9.2 Compliance shall be checked by the tests made immediately after the humidity test in the humidity cabinet or in the room in which the devices were brought to the prescribed temperature, after reassembly of covers which may have been removed.

5.9.3 For the purpose of these tests, the neutral contact and pilot contact are each considered as a pole.

5.9.4 The insulation resistance shall be measured with a dc voltage of approximately 500 V applied, the measurement being made 1 minute after application of the voltage.

5.9.5 For receptacles and connectors, the insulation resistance shall be measured consecutively:

- a) Between all poles connected together and the body. The measurement shall be made with and without a plug in engagement; and
- b) Between each pole in turn and all others, these being connected to the body, with a plug in engagement;
- c) Between any metal enclosure and metal foil in contact with the inner surface of its insulating lining, if any, a gap of approximately 4 mm (0.15 inches) being left between the metal foil and the edge of the lining.

5.9.6 For plugs, the insulation resistance shall be measured consecutively

- a) Between all poles connected together and the body;
- b) Between each pole in turn and all others, these being connected to the body;
- c) Between any metal enclosure and metal foil in contact with the inner surface of its insulating lining, if any, a gap of approximately 4 mm (0.15 inches) being left between the metal foil and the edge of the lining.

5.9.7 The term “body” includes all accessible metal parts, metal foil in contact with the outer surface of external parts of insulating material, other than the engagement face of connectors and plugs, fixing screws of bases, enclosures and covers, external assembly screws and grounding terminals, if any.

5.10 Dielectric withstand

5.10.1 Devices intended for permanent or fixed installation shall withstand without breakdown a 50 – 60 Hz essentially sinusoidal potential applied as described in Table 8 for one minute between live parts of opposite polarity and between live parts and grounding or non-current carrying immediately following the humidity conditioning and insulation resistance measurements described in Clause 5.8 and Clause 5.9.

5.10.2 Each device shall be tested by means of a 500 VA or larger capacity transformer whose output voltage is essentially sinusoidal and can be varied. The applied potential shall be increased from zero until the required test level is reached and shall be held at that level for one minute. The increase in the applied potential shall be at a uniform rate and as rapid as is consistent with its value being correctly indicated by a voltmeter.

5.10.3 If the output of the test-equipment transformer is less than 500 volt-amperes, the equipment shall include a voltmeter in the output circuit to indicate the test potential directly.

5.10.4 Devices intended for other than fixed or permanent installation and devices intended for installation on flexible cords shall be capable of withstanding the application of an ac potential of 1000V plus 2 times the rated voltage applied for a period of one minute between live parts of opposite polarity and between live parts and grounding or non-current carrying immediately following the humidity conditioning and insulation resistance measurements described in Clause 5.8 and Clause 5.9.

5.10.5 Immediately after the test, it shall be possible to engage mating plugs, receptacles, and connectors, any of which are made of thermoplastic materials. It shall be impossible to mate the plug with its intended receptacle or connector in any but the correct polarization. There shall be no deformation that results in the exposure of live parts, or to the extent affecting the intended and proper functioning of the device.

5.11 Conductor secureness

5.11.1 If a conductor of a flexible cord or cable is connected to an element (male or female contact) of a device before the element has been assembled into the device, the connection shall not break under a pull applied for 1 minute between the element and the conductor before the element has been assembled into the device.

5.11.2 While the test mentioned in Clause 5.11.1 is being performed, the angle between the element and the cord conductor shall be that used in the completely assembled device. The pullout force as specified in Table 9 shall be applied gradually.

5.12 Cord or cable secureness

5.12.1 A cord or cable connected device shall not show any evidence of damage to the flexible cord or cable, the enclosure of live parts, the strain relief means, or grounding means after the force specified in Table 10 is applied and removed. It shall be tested using both the maximum and minimum diameter flexible cord or cable that the cable grip is designed to accommodate. After being subjected to each test described and with the force removed, there shall be no axial displacement of the supply conductors, conductor insulation, or outer jacket of the flexible cord or cable from the assembled condition exceeding the maximum allowed displacement as specified in Table 10.

5.12.2 The device shall be assembled as intended onto a 30 cm (12 inch) or longer length of flexible cord or cable placed in the device with its conductors positioned as if the conductors were to be connected to the terminals. Screws, nuts, or other hardware shall be tightened according to the manufacturer's instructions. The flexible cord or cable shall be cut at a right angle to its major axis (but not stripped).

5.12.3 The cord or cable clamp shall be held firmly in place. The force shall be applied gradually and sustained for a period of 1 minute to the flexible cord or cable, at a point not less than 15 cm (6 inches) from the cord or cable grip, in a direction perpendicular to the plane of the opening and in line with the flexible cord or cable.

5.12.4 After the force in Table 10 is applied and removed, a torque shall be applied to the flexible cord or cable at a point 15 cm (6 inches) from the cord or cable grip (as specified in Table 10) for 1 minute in the direction least favorable to the clamp construction.

5.13 Impact (plugs and connectors)

5.13.1 A rewirable plug or a connector shall be fitted with a length of the maximum size flexible cord or cable, as specified in the manufacturer's instructions, that corresponds to the rating of the device.

5.13.2 The free end of the cord or cable, which shall be approximately 2250 mm (90 inches) long, shall be fixed to a wall at a height of 750 mm (30 inches) above the floor, as shown in Figure 2.

5.13.3 The device shall be held so that the cord or cable is horizontal and then allowed to fall to a concrete floor eight times. The cord or cable shall be rotated through approximately 45° at its point of fixing each time.

5.13.4 A device employing a nonmetallic enclosure or an enclosure of a zinc-based alloy shall be conditioned for 6 hours in air maintained at $-25 \pm 1^\circ\text{C}$ ($-13 \pm 1.8^\circ\text{F}$) prior to the test. Immediately following removal from the conditioning chamber, the devices shall be subjected to the impacts as described in Clauses 5.13.1 – 5.13.3.

5.13.5 As a result of the applied impacts specified in Clause 5.13.3, there shall be no cracking or breakage, deformation, loosening or detachment of parts, or other adverse effect that results in any of the following:

- a) Making uninsulated live parts or internal wiring accessible to contact by the probe illustrated in Figure 1. See Clause 4.8.3;
- b) Defeating the integrity of the enclosure so that acceptable mechanical protection is not afforded to the internal parts of the device or polarization of the device is defeated. Cracks, chips, and dents that do not adversely affect the protection against electric shock or moisture shall be disregarded;

**UL COPYRIGHTED MATERIAL –
NOT AUTHORIZED FOR FURTHER REPRODUCTION OR
DISTRIBUTION WITHOUT PERMISSION FROM UL**

- c) Interference with the operation, function, or installation of the device. The locking retaining means used to hold mating devices together is not prohibited from sustaining damage if it does not interfere with the operation or function of the devices or if it is obvious that they are damaged and must be replaced;
- d) A condition that results in the device not complying with the strain relief requirements, if applicable;
- e) A reduction of clearances and creepage distances between uninsulated live parts of opposite polarity, uninsulated live parts and accessible dead or grounded metal below the minimum acceptable values; and
- f) Any other evidence of damage that could increase the risk of fire or electric shock.

5.13.6 Immediately following the completion of this test, the devices shall be subjected to a repeated Dielectric Voltage-Withstand Test as described in Clause 5.10.

5.14 Crush

5.14.1 Devices intended to be wired onto flexible cord shall be placed between flat rigid horizontal steel plates which are large enough to cover the device with the cable installed. A crushing force shall be applied, increased gradually to a value of 1113 N (250 lbf) and held for one minute. The force shall then be gradually removed. Each device shall be oriented in a natural resting position before applying the force.

5.14.2 The flexible cord used to wire the device shall be the minimum size specified for use with the product by the manufacturer. See Clause 7.1.1.2.

5.14.3 A device employing a nonmetallic enclosure or an enclosure of a zinc-based alloy shall be conditioned for 6 hours in air maintained at $-25 \pm 1^\circ\text{C}$ ($-13 \pm 1.8^\circ\text{F}$) prior to the test. Immediately following removal from the conditioning chamber, the devices shall be subject to the crushing force as described in Clauses 5.14.1 – 5.14.2.

5.14.4 As a result of the applied force specified in Clause 5.14.1, there shall not be any cracking or breakage, deformation, or other adverse effect that results in any of the following:

- a) Making uninsulated live parts or internal wiring accessible to contact by the probe illustrated in Figure 1. See Clause 4.8.3.
- b) Defeating the integrity of the enclosure so that acceptable mechanical protection is not afforded to the internal parts of the device or polarization of the device is defeated.
- c) Interference with the operation, function or installation of the device. The locking retaining means used to hold mating devices together may sustain damage if it does not interfere with the operation or function of the devices or it is obvious they are damaged and must be replaced.
- d) A condition that results in the device not complying with the strain relief requirements, if applicable.
- e) A reduction of clearances and creepage distances between uninsulated live parts of opposite polarity, uninsulated live parts and accessible dead or grounded metal below the minimum acceptable values.

- f) Any other evidence of damage that could increase the risk of fire or electric shock.

5.14.5 Immediately following the completion of this test, the devices shall be subjected to a repeated Dielectric Voltage-Withstand test as described in Clause 5.10.

5.15 Withdrawal force

5.15.1 The pressure exerted by mating contacts of a plug with a receptacle or connector shall be sufficient to keep it from working out of the receptacle or connector in normal use. The circuit shall not be disconnected by the application of a force less than the value shown in Table 11. The force shall be applied for one minute.

5.15.2 If the plug, receptacle, and connector are of the mechanically interlocked type, the requirements of Clause 5.15.1 shall not apply.

5.15.3 Compliance shall be checked with the device fully engaged as intended, mounted so the axis of the contacts are vertical with the device openings facing downward. During the test, any manually operated locking retaining devices shall not be engaged.

5.16 Grounding (bonding) path current

5.16.1 In the United States, Clauses 5.16.1 through 5.16.4 apply. The assembly of mating grounding devices shall carry the current specified in Table 12 for the time specified in that table. The current shall be based on the minimum size equipment grounding conductor required for the ampere rating of the device. See Table 12. The components in the grounding path shall not crack, break, or melt.

5.16.2 The mating devices shall be mounted and assembled as intended. A grounding conductor of the appropriate size, not less than 0.6 m (2 feet) long, shall be connected to the grounding terminal of each device, with the terminals employed to hold the conductor tightened using a torque as specified by the manufacturer's instructions. Receptacles and power inlets shall be wired with the minimum allowable size copper building wire conductor. Plugs and connectors shall be wired with flexible, stranded conductor from flexible cord or cable sized on the basis of the ampere rating of the device. The test current shall be passed through the mating devices and grounding wires in series.

5.16.3 After having carried the current specified in Clause 5.16.1, continuity shall exist on the test assembly when measured between the grounding (bonding) conductors.

5.16.4 Any indicating device such as an ohmmeter, battery-and-buzzer combination, or the like, may be used to determine whether continuity exists.

5.17 Short circuit withstand (motor rated devices)

5.17.1 General

5.17.1.1 In the United States, a device having a motor rating of more than 1 horsepower (746 W) shall be subjected to the tests in accordance with Clauses 5.17.2.6 – 5.17.2.16 when protected by a fuse or circuit breaker as specified in Clauses 5.17.2.1 and 5.17.2.2. The overcurrent protective device used shall have an interrupting rating at least equal to the test current specified in Table 13. See Clauses 7.1.13.2 and 7.1.13.4.

5.17.1.2 If such equipment is marked to limit protection to fuses only, it shall not be considered as intended for use in a circuit protected by an inverse-time circuit breaker.

5.17.1.3 Testing with inverse-time circuit breakers shall not be required if it is shown that the clearing time of the inverse-time circuit breakers will be less than that of the fuse with which the product has been tested.

5.17.2 Protective devices

5.17.2.1 The fuses used for the tests shall be specified as follows:

- a) For a device intended for use on general purpose branch circuits, the rating of the fuse used shall be the ampere rating of the device.
- b) For a device intended for use on motor branch circuits, the fuses used for the tests shall be specified by the manufacturer in accordance with Table 14.

5.17.2.2 An inverse-time circuit breaker used for the test described in Clauses 5.17.2.6 – 5.17.2.16 shall be specified by the manufacturer in accordance with (a), (b), or (c):

- a) For a device intended for use on general purpose branch circuits, the rating of the inverse-time circuit breaker shall be the ampere rating of the device.
- b) For a device intended for use on motor branch circuits, the inverse-time circuit breaker may be rated four times the maximum full-load motor-current rating for full-load currents of 100 amperes or less or three times the maximum full-load motor-current rating for full-load currents greater than 100 amperes. If the calculated value of the circuit breaker is between two standard ratings as specified in Clause 5.17.2.4, a circuit breaker of the nearest standard rating less than the calculated value shall be used. If the calculated value of the circuit breaker is less than 15 amperes, a circuit breaker rated 15 amperes shall be used. No marking of the circuit breaker rating is required on the product.
- c) The inverse-time circuit breaker mentioned above may have a rating less than that specified in (b) if the product is marked to indicate the limit of protection.

5.17.2.3 Standard ampere ratings for fuses are 15, 20, 25, 30, 35, 40, 45, 50, 60, 70, 80, 90, 100, 110, 125, 150, 175, 200, 225, 250, 300, 350, 400, 450, 500, 600, 601, 700, 800, 1000, 1200, 1600, 2000, 2500, 3000, and 4000.

5.17.2.4 Standard ampere ratings for inverse-time circuit breakers are 15, 20, 25, 30, 35, 40, 45, 50, 60, 70, 80, 90, 100, 110, 125, 150, 175, 200, 225, 250, 300, 350, 400, 450, 500, 600, 700, 800, 1000, 1200, 1600, 2000, 2500, 3000, and 4000.

5.17.2.5 The marking referred to in Clauses 5.17.1.1, 5.17.2.2 and Table 14 may alternatively be located in the installation instructions.

5.17.2.6 A device shall be tested in an enclosure representative of that likely to be encountered in service.

5.17.2.7 A receptacle shall be wired to each of the testing terminals by 1.2 m (4 feet) of wire per pole. For a device intended for use on motor branch circuits, the wire shall be the smallest size having an ampacity of at least 125 percent of the maximum full-load motor-current ratings of the device. For a device intended for use on general purpose branch circuits, the wire shall be the smallest size having an ampacity matching the ampere rating of the device. The wire size shall be determined in accordance with NFPA 70 or CEC C22.1, as applicable, based on the wire temperature rating marked in accordance with Clauses 7.1.1.2 and 7.1.1.3. If the terminal will not receive that size of wire, the maximum allowable wire size shall be used. An attachment plug wired as specified in Clause 5.17.2.8(a) and using the same size wire shall be plugged into the receptacle.

5.17.2.8 For an attachment plug, cord connector, or inlet, each assembly shall be tested as assembled. The wire, cord, or cable used to connect each device shall be determined in accordance with NFPA 70 or CEC C22.1, as applicable, based on the wire temperature rating and minimum conductor size, if applicable, marked on the device. The grounding (bonding) conductor shall be installed as intended. For this test:

- a) An attachment plug shall be assembled to a 0.6 m (2 ft) length of flexible cord or cable. The load conductors shall be shorted together at the end. The plug shall then be inserted in a receptacle wired as described in Clause 5.17.2.7.
- b) A cord connector shall be assembled to a 1.2 m (4 feet) length of flexible cord or cable wired at one end to the testing terminals. An attachment plug, shorted as described in Clause 5.17.2.7, shall be plugged into the cord connector.
- c) An inlet shall be assembled and installed as intended. The load terminals shall be wired with a 0.6 m (2 ft) length of flexible cord or cable which is shorted together at the end. The mating cord connector shall be wired to the testing terminals by 1.2 m (4 feet) of wire.

5.17.2.9 The test wires and cord may exceed the specified length if they are in the circuit during calibration.

5.17.2.10 The grounding (bonding) conductor or the metal enclosure shall be connected through a non-time-delay, 30-ampere cartridge fuse to the electrical supply live pole judged least likely to arc to ground. The fuse referred to in Clause 5.17.1.1 shall be connected in series with the pole judged most likely to strike ground. The connection shall be made to the load side of the limiting impedance by a 10 AWG (5.3 mm²) copper wire that is 1.2 – 1.8 m (4 – 6 ft) long.

5.17.2.11 The connection may be made with 12 or 14 AWG (3.3 or 2.1 mm²) copper wire if the branch-circuit conductors the equipment is intended to be connected to are 12 or 14 AWG, respectively.

5.17.2.12 During the test, surgical cotton shall be placed at all openings, covers, flanges, joints, and the like, on the outside of the enclosure.

5.17.2.13 Equipment rated for direct current shall be tested using a direct current electrical source; alternating-current equipment shall be tested on a 60 Hertz essentially sinusoidal current electrical source. The open-circuit voltage of the test circuit shall be 100 to 105 % of the voltage rating of the device, except that the voltage may exceed 105 % of the rated voltage with the concurrence of those concerned. The test circuit shall be capable of delivering the current specified in Table 13 for a given motor rating when the system is short-circuited at the testing terminals to which the device under test is connected, and this shall be verified by means of an oscillograph.

5.17.2.14 For all test operations, the test circuit shall be closed on the mated devices. Two devices shall be tested. If an interlock is provided, the test shall be conducted with the interlock switch closed.

5.17.2.15 Air core type reactors shall be employed in the line to obtain the power factor in accordance with Table 13. The reactors may be connected in parallel, but no reactor shall be connected in parallel with a resistor, except that a reactor in any phase may be shunted by a resistor if the power consumed by the resistor is approximately 0.6 percent of the reactive volt-amperes in the reactor in that phase. The minimum value of the shunting resistance used with a reactor having negligible resistance shall be calculated by the equation:

$$R = 167 \frac{E}{I}$$

in which:

E is the voltage across the reactor with current I flowing as determined by oscillographic measurement during the short circuit calibration or by proportion from meter measurements at some lower current.

5.17.2.16 If a group of devices having different ratings are of the same construction and material and are intended for use with one size of fuse, tests on the lowest and highest ratings may be considered to be representative of that group.

5.17.2.17 After the protective device has cleared the fault, the device shall comply with the following:

- a) There shall not be any discharge of parts. The pin and sleeve contacts shall not disintegrate, evaporate, or weld. There shall not be any damage to the device, the wiring terminals or other parts that would impair the function of the device.
- b) There shall not be any breakage of insulating bases or supports to the extent that the integrity of the mounting or insulation of live parts is impaired.
- c) There shall not be any ignition of the cotton or cord insulation, or any other risk of a fire, and the circuit breaker shall operate when the test circuit is closed.

**UL COPYRIGHTED MATERIAL –
NOT AUTHORIZED FOR FURTHER REPRODUCTION OR
DISTRIBUTION WITHOUT PERMISSION FROM UL**

d) The fuse connected between the live pole and the grounding (bonding) conductor or the enclosure shall not open

5.17.3 Calibration of test circuits

5.17.3.1 General

5.17.3.1.1 The available current capacity of the circuit shall be at least the value required for the short-circuit-withstand rating of the device. The frequency of the test circuit shall be 60 ± 12 Hz.

5.17.3.2 Available current of 10,000 amperes or less

5.17.3.2.1 For an alternating-current circuit intended to deliver 10,000 amperes or less, the current and power factor shall be determined as follows:

a) For a 3-phase test circuit, the current shall be determined by averaging the rms values of the first complete cycle of current in each of the three phases; the voltage to neutral shall be used to determine the power factor.

b) For a single-phase test circuit, the current shall be the rms value of the first complete cycle (see Figure 3) when the circuit is closed to produce an essentially symmetrical current waveform. The direct-current component shall not be added to the value obtained when measured as illustrated. To obtain the desired symmetrical waveform of a single-phase test circuit, controlled closing is recommended although random closing methods may be used. The power factor shall be determined by referring the open-circuit voltage wave to the two adjacent zero points at the end half of the first complete current cycle by transposition through a suitable timing wave. The power factor shall be computed as an average of the values obtained by using these two current zero points.

5.17.3.3 Available current more than 10,000 amperes

5.17.3.3.1 For circuits intended to deliver more than 10,000 amperes, the current and power factor shall be determined in accordance with the requirements in Clauses 5.17.3.3.2 – 5.17.3.3.8. Instrumentation used to measure test circuits of over 10,000 amperes shall comply with the requirements in Clauses 5.17.3.4.1 – 5.17.3.4.11.

5.17.3.3.2 The rms symmetrical current shall be determined, with the supply terminals short-circuited by measuring the alternating-current component of the wave at an instant $1/2$ cycle – on the basis of the test frequency timing wave – after the initiation of the short circuit. The current shall be calculated in accordance with Figure 7 in ANSI/IEEE C37.09.

5.17.3.3.3 For a 3-phase test circuit, the rms symmetrical current shall be the average of the currents in the three phases. The rms symmetrical current in any one phase is not to be less than 90 percent of the required test current.

5.17.3.3.4 The test circuit and its transients shall be such that:

a) 3 cycles after initiation of the short circuit, the symmetrical alternating component of current will not be less than 90 percent of the symmetrical alternating component of current at the end of the first $1/2$ cycle; or

- b) The symmetrical alternating component of current at the time at which the overcurrent-protective device will interrupt the test circuit is at least 100 percent of the rating for which the device is being tested.

In 3-phase circuits, the symmetrical alternating component of current of all three phases shall be averaged.

5.17.3.3.5 The power factor shall be determined at an instant 1/2 cycle - on the basis of the test frequency timing wave - after the short circuit occurs. The total asymmetrical rms amperes shall be measured in accordance with Clause 5.17.3.3.2 and the ratio M_A or M_M shall be calculated as follows:

$$M_A \text{ (3 phase)} = \frac{\text{Average 3 phases-Asymmetrical rms Amperes}}{\text{Average 3 phases-Symmetrical rms Amperes}}$$

$$M_M \text{ (1 phase)} = \frac{\text{Asymmetrical rms Amperes}}{\text{Symmetrical rms Amperes}}$$

Using ratio M_A or M_M , the power factor shall be determined from Table 15.

5.17.3.3.6 The power factor of a 3-phase circuit may be calculated by using controlled closing so that upon subsequent closings a different phase will be caused to have maximum asymmetrical conditions. The power factor of each phase could then be determined using the method described for single-phase circuits in Clause 5.17.3.3.5. The power factor of the 3-phase circuit shall be considered to be the average of the power factors of each of the phases.

5.17.3.3.7 The recovery voltage shall be at least equal to the rated voltage of the device. The peak value of the recovery voltage within the first complete half cycle after clearing and for the next five successive peaks shall be at least equal to 1.414 times the rms value of the rated voltage of the device. Each of the peaks shall not be displaced by more than ± 10 electrical degrees from the peak values of the open-circuit recovery voltage - that is, the displacement of the peak from its normal position on a sinusoidal wave. The average of the instantaneous values of recovery voltage each of the first six, half cycles measured at the 45° and 135° points on the wave shall be not less than 85% of the rms value of the rated voltage of the device. The instantaneous value of recovery voltage measured at the 45° and 135° points of each of the first six, half cycles shall not be less than 75% of the rms value of the rated voltage of the device.

5.17.3.3.8 If there is no attenuation or phase displacement of the first full cycle of the recovery voltage wave when compared with the open-circuit secondary voltage wave before current flow in a circuit that employs secondary closing, the detailed measurement of recovery voltage characteristics as indicated in Clause 5.17.3.3.7 shall not be required.

5.17.3.4 Instrumentations for test currents above 10,000 amperes

5.17.3.4.1 The galvanometers in a magnetic oscillograph employed for recording voltage and current during circuit calibration and while testing shall be of a type having a flat (± 5 percent) frequency response from 50 – 1200 Hz. For fast acting fuses, current limiters, or motor-short-circuit protectors, a galvanometer may need to have a flat frequency response from 50 – 9000 Hz, or an oscilloscope may be needed to obtain accurate values of peak current, (I_p), and energy let-through, (I^2t).

5.17.3.4.2 Galvanometers shall be calibrated as described in Clauses 5.17.3.4.3 – 5.17.3.4.6.

5.17.3.4.3 When a shunt is used to determine the circuit characteristics, a direct-current calibrating voltage is normally used. The voltage applied to the oscillograph galvanometer circuit shall result in a deflection of the galvanometer approximately equivalent to that which is expected when the same galvanometer circuit is connected to the shunt and the nominal short-circuit current is flowing. The voltage shall be applied to cause the galvanometer to deflect in both directions. Additional calibrations shall be made using approximately 50% and approximately 150% of the voltage used to obtain the deflection indicated above, except that if the anticipated maximum deflection is less than 150%, such as a symmetrically closed single-phase circuit, any other suitable calibration point shall be chosen. The sensitivity of the galvanometer circuit in volts per millimeter (or volts per inch) shall be determined from the deflection measured in each case, and the results of the six trials averaged. The peak amperes per millimeter (or amps per inch) shall be obtained by dividing the sensitivity by the resistance of the shunt. This multiplying factor shall be used for the determination of the rms current as described in Clause 5.17.3.3.2.

5.17.3.4.4 A 60 Hz sine-wave potential may be used for calibrating the galvanometer circuit, using the same general method described in Clause 5.17.3.4.3. The resulting factor shall be multiplied by 1.414.

5.17.3.4.5 When a current transformer is used to determine the circuit characteristics, an alternating current shall be used to calibrate the galvanometer circuit. The value of current applied to the galvanometer circuit shall result in a deflection of the galvanometer approximately equivalent to that which is expected when the same galvanometer is connected to the secondary of the current transformer and nominal short circuit current is flowing in the primary. Additional calibrations shall be made at approximately 50% and approximately 150% of the current used to obtain the deflection indicated above except that if the anticipated maximum deflection is less than 150%, such as in a symmetrically closed single-phase circuit, any other suitable calibration point shall be chosen. The sensitivity of the galvanometer circuit in rms amperes per millimeter (or amps per inch) shall be determined in each case and the results averaged. The average sensitivity shall be multiplied by the current-transformer ratio and by 1.414 to obtain peak amperes per millimeter (or amps per inch). This constant shall be used for the determination of the rms current as described in Clause 5.17.3.3.2.

5.17.3.4.6 All the galvanometer elements employed shall line-up properly in the oscillograph, or the displacement differences shall be noted and used as needed.

5.17.3.4.7 The sensitivity of the galvanometers and the recording speed shall be such that the values of voltage, current, and power factor can be determined accurately. The recording speed shall be at least 1.5 m (60 inches) per second.

5.17.3.4.8 With the test circuit adjusted to provide the specified values of voltage and current, and with a noninductive (coaxial) shunt that has been found acceptable for use as a reference connected into the circuit, the tests described in Clauses 5.17.3.4.9 and 5.17.3.4.10 shall be conducted to verify the accuracy of the manufacturer's instrumentation.

5.17.3.4.9 With the secondary open-circuited, the transformer shall be live and the voltage at the test terminals observed to see if rectification is occurring making the circuit unacceptable for test purposes because the voltage and current will not be sinusoidal. Six random closings shall be made to demonstrate that residual flux in the transformer core will not cause rectification. If testing is done by closing the secondary circuit, this check can be omitted provided that testing is not commenced before the transformer has been live for approximately 2 seconds, or longer if an investigation of the test equipment shows that a longer time is necessary.

5.17.3.4.10 With the test terminals connected together by means of a copper bar, a single-phase circuit shall be closed as nearly as possible at the moment that will produce a current wave with maximum offset. The short circuit current and voltage shall be recorded. The primary voltage shall be recorded if primary closing is used. The current measured by the reference shunt shall be within 5 percent of that measured using the manufacturer's instrumentation, and there shall be no measurable variation in phase relationship between the traces of the same current. Controlled closing is not required for polyphase circuits.

5.17.3.4.11 When the verification of the accuracy of the manufacturer's instrumentation is completed, the reference coaxial shunt shall be removed from the circuit. The reference coaxial shunt shall not be used during the final calibration of the test circuit nor during the testing of devices.

5.18 Strength of insulating base and support

5.18.1 A device for field connection of fixed wiring shall not be damaged when 110 percent of the specified terminal tightening torque, as specified in Clause 4.11.3, is applied to the wire securing means of a pressure wire connector securing the maximum intended size conductor.

5.18.2 Damage shall be considered to have occurred if any cracking, bending, breakage or displacement of the insulating base, current carrying parts, assembly parts, or device enclosure reduces electrical clearances and creepage distances to less than those required, exposes live parts, or otherwise impairs the intended secure installation and use of the device.

5.19 No-load endurance

5.19.1 A plug, a cable connector, or a receptacle provided with an interlocked switch or circuit breaker or for disconnect use only (not for current interrupting) shall be subjected to a no-load endurance test in which the plug is completely inserted in the receptacle in the intended manner to permit its operation and then complete withdrawal, either manually or mechanically, the interlock being locked and unlocked after each complete insertion of the plug. The duration of the test shall be the same number of cycles as the total cycles (with and without load) for a device of the same rating tested for endurance under load, as in Clause 5.20, at a rate no greater than 10 per minute. During this test, there shall be no mechanical or visible damage to any of the parts, including the interlocking mechanism. These devices shall be marked in accordance with Clause 7.1.4.1.

5.19.2 Devices need not be marked in accordance with Clause 7.1.4.1 if tested in accordance with Clause 5.20.

5.19.3 Devices provided with an interlocking mechanism need not be marked in accordance with Clause 7.1.4.1.

5.20 Endurance with load

5.20.1 Devices intended for current interrupting shall withstand, without harmful effects as described in Clause 5.20.8, the mechanical, electrical, and thermal stresses occurring in normal use.

5.20.2 Devices under test shall be operated manually or mechanically at rated voltage and current at a rate no greater than 10 cycles per minute.

5.20.3 The test shall either be conducted using direct current or be conducted using alternating current if the device is marked in accordance with Clause 7.1.6.1. When alternating current is used, the power factor of the load shall be from 0.75 – 0.80.

5.20.4 For dual-rated devices, a test on ac may be waived if acceptable results have been obtained from an equivalent or higher volt-ampere test at a dc potential that is equal to or greater than the ac potential rating.

5.20.5 If the test is run mechanically, the rate of operation shall not be greater than 10 cycles per minute, with an average velocity of 760 ± 80 mm (30 ± 3 inches) per second in each direction.

5.20.6 A rate of operation having a lower average velocity may be used if agreeable to all parties concerned.

5.20.7 The total number of operating cycles shall be in accordance with Table 16.

5.20.8 During the test, sustained arcing shall not occur. After the test, the devices shall not show:

- a) Wear impairing the further use of the device;
- b) Deterioration of enclosures or barriers;
- c) Damage to the entry holes for the contacts that impairs proper working; and
- d) Loosening of electrical or mechanical connections.

5.21 Overload

5.21.1 When rated for current interrupting in accordance with Clause 6.1.5, a receptacle or a cable connector, and a plug shall be subjected to the overload test described in Clauses 5.21.4 – 5.21.10. This requirement does not apply to a receptacle interlocked with an integral switch or circuit breaker, in which the switch or circuit breaker is opened before the plug can be inserted or withdrawn.

5.21.2 There shall be no electrical or mechanical failure of the device, no burning or pitting of the contacts that would affect the intended function, and no welding of the contacts. The line fuse or the grounding fuse described in Clauses 5.21.9 and 5.21.10 shall not open during the test.

5.21.3 Contacts of the plug or the receptacle are not to be adjusted, lubricated, or otherwise conditioned before or during the test. An additional material intended to reduce or confine the arcing in the contact chamber of a plug and receptacle that decomposes or is otherwise affected by the arcing shall be removed for all of the overload tests.

5.21.4 The device under test shall be subjected to the overload condition by manually or mechanically inserting and withdrawing the plug into and out of the receptacle or connector for 50 cycles of operation at a rate not higher than 10 cycles per minute.

5.21.5 The plugs shall be connected to a load such that the devices shall make and break 150% of the rated current. The test shall be conducted using direct current or be conducted using alternating current if the device is marked in accordance with Clause 7.1.6.1. When alternating current is used, the power factor of the load shall be from 0.75 – 0.80.

5.21.6 The potential of the test circuit is to be from 95 to 105 percent of the rating of the device in volts.

5.21.7 The test on a receptacle and a plug that have multiple voltage and ampere ratings shall be performed at:

- a) 150 percent of the rated current that corresponds to the maximum rated voltage;
- b) 150 percent of the maximum rated current at the corresponding rated voltage; and
- c) 150 percent of the rated current at the corresponding rated voltage that results in maximum power per pole.

5.21.8 A test on alternating current may be waived if adequate results have been obtained from an equivalent or higher volt-ampere test at a direct current potential equal to or greater than the alternating current potential rating.

5.21.9 The device shall be mounted and wired to represent service conditions. Exposed metal parts shall be connected through a fuse to:

- a) Ground;
- b) The grounded conductor of the test circuit; or
- c) In the United States, a circuit conductor that differs by at least the rated potential from one or more of the remaining conductors in the circuit.

5.21.10 The fuses in the test circuit shall be non time-delay, general-use cartridge type fuses. The fuse in the grounding (bonding) conductor circuit shall have a 15 ampere rating if the device under test is rated at 30 amperes or less. If the device under test is rated at more than 30 amperes, the grounding fuse shall have a rating of 30 amperes. For the line fuse, the next higher commercial fuse rating than the value shall be used.

5.22 Abnormal overload

5.22.1 When rated for disconnecting use only, not for current interrupting (see Clause 6.1.5), a receptacle or a cable connector, and a plug shall be subjected to the overload test described in Clauses 5.22.4 – 5.22.10. This requirement does not apply to a receptacle interlocked with an integral switch or circuit breaker, in which the switch or circuit breaker is opened before the plug can be inserted or withdrawn.

5.22.2 The device need not function after the completion of the test, and shall not be used for any further tests. The ground fuse shall not open during the test. The line fuse is not prohibited from opening during the test.

5.22.3 Contacts of the plug or the receptacle shall not be adjusted, lubricated, or otherwise conditioned before or during the test. An additional material intended to reduce or confine the arcing in the contact chamber of a plug and receptacle that decomposes or is otherwise affected by the arcing shall be removed for all of the overload tests.

5.22.4 The device under test shall be subjected to the overload condition by manually or mechanically inserting and withdrawing the plug into and out of the receptacle or connector. A device rated for use with direct current shall be subject to one cycle of operation. A device rated for use with alternating current shall be subject to three cycles of operation at a rate not faster than 10 cycles per minute.

5.22.5 The plugs shall be connected to a load such that the devices shall make and break 150% of the rated current. The test shall be conducted using direct current or be conducted using alternating current if the device is marked in accordance with Clause 7.1.6.1. When alternating current is used, the power factor of the load shall be from 0.75 – 0.80.

5.22.6 The potential of the test circuit shall be from 95 to 105 percent of the rating of the device in volts.

5.22.7 The test on a receptacle and a plug that have multiple voltage and ampere ratings shall be performed at:

- a) 150 percent of the rated current that corresponds to the maximum rated voltage;
- b) 150 percent of the maximum rated current at the corresponding rated voltage; and
- c) 150 percent of the rated current at the corresponding rated voltage that results in maximum power per pole.

5.22.8 A test on alternating current may be waived if adequate results have been obtained from an equivalent or higher volt-ampere test at a direct current potential equal to or greater than the alternating current potential rating.

5.22.9 The device shall be mounted and wired to represent service conditions. Exposed metal parts shall be connected through a fuse to:

- a) Ground;
- b) The grounded conductor of the test circuit; or
- c) In the United States, a circuit conductor that differs by at least the rated potential from one or more of the remaining conductors in the circuit.

5.22.10 The fuses in the test circuit shall be non time-delay, general use, cartridge type fuses. The fuse in the grounding (bonding) conductor circuit shall have a 15 ampere rating if the device under test is rated at 30 amperes or less. If the device under test is rated at more than 30 amperes, the grounding fuse shall have a rating of 30 amperes. For the line fuse, the next higher commercial fuse rating than the value of the test current in the test circuit shall be used.

5.23 Horsepower rated locked rotor

5.23.1 In the United States, a device with one or more motor rating(s) shall perform in an overload test making and breaking the locked-rotor current corresponding to each horsepower rating of the device. There shall be no electrical or mechanical failure of the device, no burning or pitting of the contacts that would affect the intended function, and no welding of the contacts.

5.23.2 The test shall be conducted in accordance with Clause 5.21, except that the value of the test current corresponding to a horsepower rating shall be as specified in:

- a) UL 20 or CSA C22.2 No. 111 for two horsepower or less; and
- b) UL 508 or CSA C22.2 No. 14 for an alternating-current rating of more than two horsepower.

The load for an alternating-current horsepower rating shall have a power factor of 0.40 – 0.50.

5.24 Electromagnetic (pilot contacts)

5.24.1 The pilot contacts of a plug, connector, inlet, and receptacle for controlling a contactor, a relay, or other magnetically operated device shall perform satisfactorily when subjected to an overload test consisting of 50 operations, making and breaking the inrush current based on the contact rating, followed by 6,000 operations at normal rated current, in a circuit of 110% of the test potential indicated test in Table 17. The load shall be as indicated in Table 17 and shall consist of an electromagnet representative of the load that the device is intended to control.

5.24.2 A load other than one of those described in Table 17 may be used after due consideration of:

- a) The need for a device to control an electromagnetic load having other characteristics;
- b) The means utilized for matching the rating of the device to that of the load; and
- c) The manufacturer's markings.

5.25 Temperature rise

5.25.1 If the tests are conducted at an ambient temperature of other than 25°C, the results shall be adjusted to an ambient temperature of 25°C by adding the appropriate variation between 25°C and the ambient.

5.25.2 The temperature rise of a device measured at the points described in Clause 5.25.3 shall not exceed 30°C when the device is carrying its maximum rated current. This temperature rise is based on devices intended to be wired with conductors rated 60°C. A temperature rise of 45°C shall be permitted when the device is intended to be wired with conductors rated 75°C or higher, and so marked. Devices intended for use with conductors rated 75°C or higher and so marked shall not intermate with similar devices not so marked. See Clauses 7.1.1.3 and 7.1.1.4.

5.25.3 The temperature measurement shall be made on the wiring terminals of the equipment, if they are accessible for mounting thermocouples. If the equipment has no wiring terminals or if they are inaccessible, temperatures shall be measured as close as possible to the face of the equipment on the plug contacts inserted in the receptacle.

5.25.4 The temperature test shall be made following the overload test on the equipment, and shall continue for 4 h or until thermal stabilization is attained. Thermal stabilization shall be considered to have occurred when three successive readings, taken at intervals of not less than 10 minutes, show no further increases. Each connection to the equipment under test shall be made by means of at least 0.46 m (18 inches) of the intended type and size of wire or cord (see Clauses 4.11.1 and 7.1.1.2) with the terminals of the device tightened using a torque as specified by the manufacturer's instructions. In the case of a connector body, conductors of the indicated ampacity shall be used regardless of the size of the cord that is intended to be used with the device. The contacts of equipment under test shall be connected together by means of an inserted plug. A previously untested plug may be used. The terminals of the plug shall be short circuited by means of the shortest feasible lengths of the wire as previously described.

5.26 Resistance to arcing

5.26.1 If a material, other than ceramic, is used in the construction of the face of an outlet device in a way that the material is likely to be exposed to arcing while in service, the devices that were subjected to 50 cycles of operation in the overload test described in Clause 5.21 shall perform acceptably when subjected to an additional 200 cycles of operation under the overload-test conditions following the temperature test. There shall be no electrical tracking, formation of a permanent carbon conductive path, or ignition of the material. The attachment plug used for this test may be changed after every 50 operations. If a contact failure occurs after the first 50 operations, the contact may be replaced to permit the remainder of the test operations to be completed.

5.26.2 An interlocked receptacle (outlet) or a device identified as not intended for interrupting current need not be subjected to this test; see Clause 7.1.4.1.

5.26.3 Alternatively, one set of devices may be subjected to the 50 cycles of operation in the overload test described in Clause 5.21, followed by the temperature test on the devices, and then, to determine resistance to arcing, a second set of devices, previously untested, may be subjected to 250 cycles of operation under the overload-test conditions.

5.27 Polarization integrity

5.27.1 Compliance with the requirements specified in Clause 4.9.11 shall be determined by using the device assembled in its intended housing with the polarization feature removed. With the axis of the mating devices aligned, the devices shall not be able to mate in any manner that would energize the grounding (bonding) feature of the device when a force of 180 N (40 lbf) is applied.

5.28 Resistance to corrosion

5.28.1 Ferrous parts, including enclosures, shall be adequately protected against corrosion.

5.28.2 Compliance shall be checked by the following test. All grease shall be removed from the parts to be tested, by immersion in ethyl acetone, acetone or methylethyl ketone for 10 minutes. The parts shall then be immersed for 10 minutes in a 10 percent solution (by weight) of ammonium chloride in water at a temperature of $20 \pm 5^\circ\text{C}$.

5.28.3 The parts shall then be dried for 10 minutes in a heating cabinet at a temperature of $100 \pm 5^\circ\text{C}$, and their surfaces shall not show any signs of rust.

5.28.4 Traces of rust on sharp edges and yellowish film removable by rubbing shall be ignored.

5.28.5 Small helical springs and the like, and inaccessible parts exposed to abrasion, shall be considered protected against corrosion by a coating of grease. Such parts shall be tested only when the effectiveness of the grease film is in doubt, and the test shall then be made without previous removal of the grease.

5.29 Moisture resistance

5.29.1 Details

5.29.1.1 Marine-type and water-tight plugs, receptacles, and connectors requiring a degree of moisture protection shall not permit the entrance of water when subjected to the tests associated with their classifications, as described in this Clause. Water shall not:

- a) Enter the devices to any appreciable extent;
- b) Collect on the interior of the box;
- c) Interfere with the intended performance of the device; or
- d) Reach live parts.

5.29.1.2 When tested as described in Clause 5.29.2.1, a device or assembly of parts (hereinafter referred to as the test assembly), as mentioned in Clause 5.29.1.3, shall comply with Clause 5.29.2.1.

5.29.1.3 The test assembly shall be fitted with cable or conduit and installed as intended in actual service in accordance with the assembly and installation instructions. Receptacles shall be mounted on a vertical surface, with any drains present in the lowest position.

5.29.2 Marine type (shipboard use)

5.29.2.1 In the United States, the test assembly shall be subjected to a solid stream of water from a nozzle not less than 25.4 mm (1.0 in) inside diameter and under a pressure of 103 kPa (15 pounds-per-square-inch). The nozzle shall be directed at the test assembly from a distance of 3.05 m (10 ft) for 5 minutes.

5.29.2.2 In the United States, if the device employed in the test assembly is an outlet, the test described in Clause 5.29.2.1 shall be conducted both with and without an attachment plug in the outlet.

5.29.3 Watertight

5.29.3.1 In the United States, the test assembly shall consist of a mated plug and receptacle, a mated plug and connector, a mated connector and power inlet, an individual device with a cap or cover, or any other combination of mating devices.

5.29.3.2 In the United States, the test assembly shall be immersed for 24 hours in water at a temperature of $25 \pm 5^\circ\text{C}$, the highest point of the assembly being approximately 51 mm (2.0 in) below the water level and the longitudinal axis being parallel to the surface of the water.

5.30 Environmental enclosure type designators

5.30.1 A device marked with an enclosure type designation shall be subjected to the tests specified in UL 50 or CAN/CSA-C22.2 No. 94 and shall comply with the construction requirements applicable to an enclosure of the type number or numbers with which it is marked. See Clauses 7.1.14.1 – 7.1.14.5.

5.30.2 A watertight connection at conduit entrances shall be a conduit hub or the equivalent, such as a knockout or fitting, located so that when conduit is connected and the enclosure is mounted in the intended manner, the enclosure is found to be acceptable when subjected to the tests specified in UL 50 or CAN/CSA-C22.2 No. 94.

5.30.3 When a panel mounted device is tested, it shall be mounted on a panel of the appropriate enclosure type, in accordance with the manufacturer's instructions.

6 Ratings

6.1 General

6.1.1 Devices shall be rated in amperes and in volts, ac or dc, or both. A device may have multiple voltage and current ratings unless designed for a single voltage and current rating.

6.1.2 If the contact configuration of the device is one of the configurations illustrated in UL 1686, the device shall be given only the ratings shown in the figure.

6.1.3 In the United States, a device may be rated in horsepower in addition to the required ampere rating.

6.1.4 If a device includes a switch that controls an outlet, the overall rating of the device shall not be higher than the rating of the switch.

6.1.5 A device shall be rated for disconnecting use only, not for current interrupting, if:

- a) The voltage rating is higher than 250 V dc; or
- b) The current rating is higher than 250 A for voltages up to 300 V ac, or 200 A for voltages over 300 V ac and for voltages up to 250 V dc. See Clause 5.21.5.

7 Markings

Advisory Note: *In Canada, there are two official languages, English and French. Annex B lists acceptable French translations of the markings specified in this standard. All markings required by this standard may have to be in other languages to conform with the language requirements where the product is to be used.*

7.1 Details

7.1.1 Company name, catalog designation, electrical rating

7.1.1.1 A device shall be legibly and permanently marked, where readily visible after installation, with:

- a) The manufacturer's name, trade name, trademark, or other descriptive marking by which the organization responsible for the device may be identified. The manufacturer's identification may be in a traceable code if the device is identified by the brand or trademark owned by a private labeler;
- b) The catalog number or an equivalent designation, where practicable. See Clause 7.1.8.1;
- c) The electrical rating in both volts and amperes;
- d) In the United States, the motor rating(s) and associated electrical rating (voltage, no. of phases, etc.), if so rated;
- e) Whether ac or dc, or both, see Clause 7.1.6.1;
- f) For devices incorporating either fuses or circuit breakers, the rating of the fuse or circuit breaker in rms symmetrical amperes;
- g) Ambient temperature rating, if higher than 40°C or if lower than -25°C; and
- h) If intended for a specific location, the type of location in which the device is intended to be used.

7.1.1.2 A device intended for use with flexible cord or cable shall be marked with the following:

- a) The intended flexible cord or cable types;
- b) Conductor size or sizes;
- c) Total number of conductors; and

**UL COPYRIGHTED MATERIAL –
NOT AUTHORIZED FOR FURTHER REPRODUCTION OR
DISTRIBUTION WITHOUT PERMISSION FROM UL**

- d) The overall cord diameter if the device is intended to be utilized with a limited range of cord diameters available for a cord.

The markings shall be indicated on the smallest unit shipping carton, on an instruction sheet provided in the carton, or on the device.

7.1.1.3 In the United States, if the device is rated 100 A or less and is intended for use with conductors having 75°C insulation, the device shall be marked with the temperature rating of the insulation. In Canada, if the device is designed for use with conductors having other than 60°C insulation, the device shall be marked with the temperature rating of the insulation.

7.1.1.4 If a device is intended for use with conductors having a temperature rating higher than 60°C but is intended to be used based on 60°C ampacities, the minimum conductor size shall be indicated on the device, as well as on the smallest unit shipping carton, or on an instruction sheet provided in the carton.

7.1.2 Multiple factories

7.1.2.1 In the United States, if a manufacturer produces or assembles attachment plugs, receptacles, cord connectors, and the like at more than one factory, each finished device shall have a distinctive marking on the device, which may be in code, by which the device can be identified as the product of a particular factory.

7.1.3 Nonconductive mounting means

7.1.3.1 In the United States, a receptacle or a flanged inlet as described in Clause 4.9.4 shall be plainly marked on the device where visible during installation as follows: "CAUTION – Mounting means not grounded. Grounding (bonding) wire connection required" or an equivalent statement following the word "CAUTION". See Clause 7.1.5.1.

7.1.4 Disconnecting under load

7.1.4.1 A device not intended for interrupting current shall be marked "CAUTION – Risk of Electric Shock Do Not Disconnect Under Load", or an equivalent statement following the word "CAUTION". This marking shall be visible while the device is in the mated condition. See Clause 7.1.5.1.

7.1.5 Cautionary marking size

7.1.5.1 Markings containing the word “CAUTION” shall contrast sharply with the background and shall appear in lettering of a height not less than specified in Table 18. The word “CAUTION” shall be not less than twice the height specified in Table 18.

7.1.6 AC only devices

7.1.6.1 A device that is intended for use on alternating current circuits only shall be identified as such by means of the letters “AC”, or “AC Only”, or an acceptable frequency marking (for example, “60 Hertz or 60 ~”), or a phase marking, which shall be a part of the electrical rating. For multiphase devices that are intended for use only on a Wye system, the marking shall include the word “Wye,” or the equivalent.

7.1.7 Enclosure grounded (or bonded) devices

7.1.7.1 A metallic attachment plug or cord connector in which the enclosure is conductively connected to the grounding pin or contact shall be marked on the device, “enclosure grounded” or with an equivalent statement, unless the grounding (or bonding) connection is readily visible.

7.1.8 Catalog designation

7.1.8.1 If the product is too small, or where it would be difficult to legibly provide the complete catalog designation or an equivalent designation, or where several catalog numbers use common parts, the complete designation shall appear on the smallest unit container.

7.1.9 Fused devices

7.1.9.1 A device intended to accommodate fuses, other than a plug or cartridge fuse acceptable for branch circuit protection, shall be marked “Use only with a ___ volt fuse”. The potential to be used in the marking shall be the voltage rating of the fuse for which the device is intended.

7.1.10 Locking-type devices

7.1.10.1 An attachment plug required to be given a twisting or turning motion, except for any locking retaining device, to lock or unlock it after the male contacts have been inserted into the female contacts, and a cord connector intended to accommodate such an attachment plug, shall be marked on the device, “Turn and pull” or an equivalent wording or symbol. The marking shall be visible while the device is in use.

7.1.11 Receptacle marking location

7.1.11.1 The markings required in Clauses 7.1.1.1, 7.1.4.1, and 7.1.6.1 shall be visible on the outside of a receptacle after installation.

7.1.12 Wiring information – field wiring terminals

7.1.12.1 The value of tightening torque assigned in accordance with Clause 4.11.3 shall be marked where readily visible:

- a) On the device;
- b) On the smallest unit container; or
- c) On an information sheet packed in the smallest unit container.

7.1.12.2 If field wiring terminals employing solder connections are intended for solid, stranded tinned, or tin dipped stranded conductors only, instructions regarding the use of solid wire or the tinning of stranded wire shall be marked where readily visible:

- a) On the device;
- b) On the smallest unit container; or
- c) On an information sheet packed in the smallest unit container.

7.1.12.3 Crimp terminal installations instructions, including conductor size(s) and type(s) and crimp tool(s) designation shall be marked where readily visible:

- a) On the device;
- b) On the smallest unit container; or
- c) On an information sheet packed in the smallest unit container.

7.1.13 Overcurrent protection – motor rated devices

7.1.13.1 In the United States, a device intended for use on general purpose branch circuits having a motor rating over 1 horsepower (746 W) shall be marked "Suitable For Use On A Circuit Capable Of Delivering Not More Than _____ rms Symmetrical Amperes, _____ Volts Maximum". The ratings shall not be more than the value for which the device was tested in accordance with Clause 5.17.

- a) If tested only with non-time delay fuses, the marking shall also include the following or equivalent statement:

"When Protected by _____ Class Fuses".

- b) If tested with a time delay fuse, the marking shall also include the following or equivalent statement:

"When Protected by Time Delay _____ Class Fuses".

- c) If tested in accordance with Clause 5.17.2.2, the marking shall also include the following or equivalent statement:

"When Protected by a Circuit Breaker Having an Interrupting Rating Not Less than _____ rms Symmetrical Amperes, _____ Volts Maximum".

These markings shall be located on the device or in the installation instructions.

7.1.13.2 A motor rated device intended for use on general purpose branch circuits shall also be marked on the device with one of the following statements:

- a) "Maximum Overcurrent Protection Shall Not Exceed the Ampere Rating of This Device" or the equivalent,
b) "Maximum Overcurrent Protection _____ Amperes",
c) "Protect With Maximum _____ Ampere Fuses", or
d) "Protect With Maximum _____ Ampere Time Delay Fuses".

The amperes rating shall not be more than the rating of the device.

7.1.13.3 A device intended only for use on a motor branch circuit having a motor rating over 1 horsepower (746 W) shall be marked "Suitable For Use On A Circuit Capable Of Delivering Not More Than _____ rms Symmetrical Amperes, _____ Volts Maximum". The ratings shall not be more than the value for which the device was tested in accordance with Clause 5.17.

- a) If tested only with non-time delay fuses in accordance with Table 14, the marking shall also include the following or equivalent statement:

"When Protected by _____ Class Fuses".

- b) If tested with a time delay fuse in accordance with Table 14, the marking shall also include the following or equivalent statement:

UL COPYRIGHTED MATERIAL –
NOT AUTHORIZED FOR FURTHER REPRODUCTION OR
DISTRIBUTION WITHOUT PERMISSION FROM UL

“When Protected by Time Delay _____ Class Fuses”.

c) If tested in accordance with Clause 5.17.2.2, the marking shall also include the following or equivalent statement:

“When Protected By A Circuit Breaker Having An Interrupting Rating Not Less Than _____ rms Symmetrical Amperes, _____ Volts Maximum”.

These markings shall be located on the device or in the installation instructions.

7.1.13.4 A motor rated device intended only for use on a Motor branch circuit shall also be marked with the following:

- a) “Suitable for Use Only on Motor Branch Circuits”, or the equivalent, and
- b) “Maximum Overcurrent Protection _____ Amperes”, or
- c) “Protect With Maximum _____ Ampere Fuses”, or
- d) “Protect With Maximum _____ Ampere Time Delay Fuses”.

The ampere rating shall not be more than the value for which the device was tested in accordance with Clause 5.17.2.1 or 5.17.2.2.

7.1.14 Environmental enclosures

7.1.14.1 A device enclosure type designation marking shall be one of those specified in UL 50 or CAN/CSA-C22.2 No. 94. The marking shall be visible after installation and shall be permanent. See Clauses 7.1.14.6 and 7.1.14.7.

7.1.14.2 An enclosure that complies with the requirements for more than one type of enclosure may be marked with multiple designations.

7.1.14.3 Device enclosures that comply with the requirements of Clause 5.29 may be provided with the following additional markings:

- a) In the United States, a Type 4, 4X, 6, or 6P enclosure may be marked “Watertight”.
- b) In Canada, a Type 6 or 6P enclosure may be marked “Watertight”.
- c) A Type 4X or 6P enclosure may be marked “Corrosion Resistant”.

7.1.14.4 If the acceptability of a Type 2, 3, or 3R enclosure is dependent upon a particular mounting orientation, the device enclosure shall be marked to indicate the required orientation.

7.1.14.5 A plug, receptacle, or connector that provides enclosure protection shall be legibly marked where visible during intended use with the following or equivalent statement, "To maintain enclosure rating, use only with a device with identical marking _____" (specific identification).

7.1.14.6 A marking identifying an environmental enclosure type or types shall be molded, die-stamped, paint-stenciled, stamped or etched metal that is permanently secured, or indelibly applied lettering on a label secured by adhesive that, upon investigation, is acceptable for the application. Ordinary usage, including likely exposure to weather and other ambient conditions, handling, storage, and the like of the equipment is considered in the determination of the acceptability of the application.

7.1.14.7 A pressure-sensitive label or a label secured by cement or adhesive shall comply with the applicable requirements for indoor or outdoor use labels in UL 969 or CSA C22.2 No. 0.15.

7.1.15 Moisture-resistant devices

7.1.15.1 A device that complies with the requirements of Clause 5.29.3 may be marked "Watertight".

7.1.15.2 In the United States, a device that complies with the requirements of Clause 5.29.2 may be marked "Marine type".

7.2 Identification and marking of terminals

7.2.1 General

7.2.1.1 Wiring terminals shall be marked to indicate the proper connections for the power, control circuits, and the like, or a wiring diagram coded to the terminal marking shall be provided with the product.

7.2.2 Grounded and grounding (or bonding)

7.2.2.1 Device wiring terminals intended for connection to grounded circuit conductors or grounding (or bonding) conductors shall be clearly and permanently identified on the device in accordance with Table 19 or 20. The colors or markings specified for this terminal identification shall not be applied to other than the designated terminals. The identifications shall be readily recognizable during wiring and relate directly to the appropriate terminals.

7.2.2.2 Terminals for the grounded conductors may be permanently identified at the time of installation by a distinctive white marking or other equivalent means.

7.2.2.3 A part relied upon to provide the terminal identification required in Clause 7.2.2.1 shall not be readily removable if it can be replaced with a similar part of another wiring terminal of the device. A suitably staked terminal screw shall be considered not readily removable for this purpose. A surface of a permanent appendage to a wiring terminal may be used to mark the terminal identification.

7.2.3 Other terminals

7.2.3.1 Marking conventions, other than for those terminals described in Clause 7.2.2.1, shall be provided and shall be identical to the convention used on the mating device. The marking convention used shall be described in the wiring instructions provided with the device.

Table 1
Hot wire ignition (HWI) and high-current arc resistance
to ignition (HAI) ratings of insulating materials
(See Clauses 4.3.12 and 4.3.13)

Flammability classification ^b	HWI ^{c,e}		HAI ^d	
	Maximum PLC ^a	Minimum value	Maximum PLC ^a	Minimum value
V-0, VTM-0	4	7	3	15
V-1, VTM-1, 5VA, 5VB	3	15	3	15
V-2, VTM-2	3	15	3	15
HB	2	30	1	60

^a For materials with other than VTM flammability classifications, the performance level class (PLC) for material shall be evaluated using the specimen thickness employed in the end product or nominal 3.2 mm (1/8 inch) thickness, whichever thickness is greater.

^b Flammability classification- Described in UL 94 or CAN/CSA-C22.2 No. 0.17. The flammability classification shall be judged at the actual minimum thickness employed within 0.8 mm (1/32 inch) of live parts within the device.

^c Hot Wire Resistance to Ignition – Described in UL 746A or CAN/CSA-C22.2 No. 0.17.

^d High-current arc resistance to ignition – Described in UL 746A or CAN/CSA-C22.2 No. 0.17.

^e The requirements for hot wire ignition (HWI) performance level class values do not apply to a polymeric material used as an enclosure of a portable device that does not enclose live parts or insulated live parts where the insulation thickness is greater than 0.7 mm (0.028 inch).

Table 2
Minimum relative thermal indices of insulating materials
(See Clause 4.3.17)

Application	Minimum relative thermal index ^a , Degrees C		
	Electrical	Mechanical ^b	
		With impact	Without impact
ELECTRICAL INSULATION All devices	80	60	80
ENCLOSURE or parts of an ENCLOSURE			
A. All permanently wired devices and other devices containing fuses	80	60	80
B. All other devices	60	60	60

^a Relative thermal index – Described in UL 746B or CAN/CSA-C22.2 No. 0.17. In the United States, for materials with other than VTM flammability classifications, the material shall be evaluated using specimen thickness of no more than the thickness employed in the end product or nominal 3.2 mm (1/8 inch) thickness, whichever is greater. In Canada, for materials with other than VTM flammability classifications, the material shall be evaluated using specimen thickness of no more than the thickness employed in the end product or nominal 1.6 mm (1/16 inch) thickness, whichever is greater.

^b For filament wound tubing, industrial laminates, vulcanized fiber and similar polymeric materials, the minimum RTI for mechanical shall be the values specified for Electrical.

Table 3
Minimum acceptable sizes of grounding
(bonding) conductors
(See Clauses 4.10.1 and 4.10.3)

Device rating, amperes	Copper grounding conductors ^{a, b, c}	
	Not exceeding	AWG
15	14	(2.1)
20	12 ^b	(3.3)
30	10	(5.3)
40	10	(5.3)
60	10	(5.3)
100	8	(8.4)
200	6	(13.3)
300	4	(21.2)
400	3	(26.7)
500	2	(33.6)
600	1	(42.4)
800	1/0	(53.5)

^a Equivalent metric cross-sectional area provided for reference only.
^b In Canada, the minimum acceptable sizes of grounding conductors are 14 AWG for 20A rated devices and 12 AWG for 30A rated devices.
^c In Canada, the terminals of a device intended to accommodate an 8 AWG or larger conductor shall also be capable of securing a compact copper stranded construction.

Table 4
Minimum sizes of wire binding screws
(See Clauses 4.11.7 and 4.11.8)

Contact rating, Amperes	Minimum size of screw	Minimum head diameter	Maximum number of threads per inch
20 or less	#6 ^a	0.275 in	36
20 or less	M3.5 ^a	7.0 mm	-
up to 35	#8 ^b	0.315 in	32
up to 35	M4 ^b	8.0 mm	-

^a An M3 (No. 6) terminal screw, minimum head diameter 6.3 mm (1/4 inch), may be used on devices not intended for permanent installation and rated at 15 A.
^b A (No. 8) or larger screw having more than the number of threads per inch indicated may be used for terminals if the assembly is capable of withstanding a tightening torque of 1.8 N•m (16 lbf in) applied to the wire-binding screw without stripping either the screw threads or the terminal plate threads, or damaging the slot in the head of the screw. See Clause 4.11.8.

Table 5
Voltage for tests
(See Clause 5.1.2)

Device rating ^a , volts	Test potential in volts
110 - 120, ac	120, ac
110 - 125, dc	125, dc
208, ac	208, ac
220 - 240, ac	240, ac
220 - 250, dc	250, dc
265 - 277, ac	277, ac
347, ac	347, ac
440 - 480, ac	480, ac
550 - 600, ac	600, ac
550 - 600, dc	600, dc

^a If the rating of the device does not fall within any of the indicated voltage ranges, it shall be tested at its rated voltage.

Table 6
Applicable tests
(See Clause 5.1.6)

Test	Product			
	Plugs	Connectors	Receptacles	Inlets
Accelerated Aging ^{a,j}	X	X	X	X
Comparative Tracking Index ^b	X	X	X	X
Glow Wire ^b	X	X	X	X
High-Current Arc Resistance to Ignition ^b	X	X	X	X
Mold Stress ^a	X	X	X	X
Moisture Absorption Resistance ^{a,b}	X	X	X	X
Humidity ^c	X	X	X	X
Insulation Resistance ^c	X	X	X	X
Dielectric Withstand ^c	X	X	X	X
Conductor Secureness ^d	X	X		
Cord or Cable Secureness ^a	X	X		
Impact ^a	X	X		
Crush ^a	X	X		
Withdrawal Forces ^a		X		
Ground Path Current ^{a,e}	X	X		X
Short Circuit Withstand ^{a,k}	X	X	X	X
Strength of Insulating Base and Support ^a			X	X
No-Load Endurance ^f		X	X	
Endurance with Load ^f		X	X	
Overload ^g		X	X	
Horsepower Rated Locked Rotor		X	X	
Electromagnetic ^m		X	X	
Abnormal Overload ^h		X	X	
Temperature Rise ^g		X	X	
Resistance to Arcing ^g		X	X	
Polarization Integrity ^{e,h}	X	X	X	X
Resistance to Corrosion ^a	X	X	X	X
Moisture Resistance ^{a,n}	X	X	X	X

**UL COPYRIGHTED MATERIAL –
NOT AUTHORIZED FOR FURTHER REPRODUCTION OR
DISTRIBUTION WITHOUT PERMISSION FROM UL**

Table 6 Continued on Next Page

Table 6 Continued

Test	Product			
	Plugs	Connectors	Receptacles	Inlets
Environmental Enclosure Type Designators	X	X	X	X
<p>^a Each of these tests shall be performed on a separate device.</p> <p>^b Based on properties of insulating materials. Refer to construction requirements.</p> <p>^c The humidity, insulation resistance, and dielectric strength tests shall be performed on the same device.</p> <p>^d Factory-wired devices only.</p> <p>^e Required for specific grounding constructions only. Refer to test description.</p> <p>^f These tests are performed alternately on the same device.</p> <p>^g The overload, temperature rise, and resistance to arcing tests shall be performed on the same device.</p> <p>^h Mated pairs shall be provided.</p> <p>ⁱ For device enclosures identified by a Type no. or nos. for environmental protection.</p> <p>^j Pliable rubber or pliable vinyl chloride elastomeric devices only.</p> <p>^k Motor rated devices only.</p> <p>^m For devices employing pilot contacts.</p> <p>ⁿ For marine and watertight devices.</p>				

Table 7
High-current arc resistance to ignition test
(See Clause 5.5.1)

Flame class	Arcing criteria	No. of arcs
HB		60
V-2, VTM-2		15
V-1, VTM-1, 5VA, 5VB		15
V-0, VTM-0		15

Table 8
Dielectric withstand test voltage
(See Clause 5.10.1)

Device rating, volts	Test voltage, volts
Up to and including 300	2000
Over 300 up to and including 600	3000

Table 9
Test values for conductor secureness test
(See Clause 5.11.2)

Size of conductor		Pullout force	
AWG or kcmil	mm ²	N	pounds
30	0.05	2.2	0.5
28	0.08	4.5	1
26	0.13	8.9	2
24	0.20	13.4	3
22	0.32	20	4.5
20	0.52	30	6.75
18	0.82	30	6.75
16	1.3	40	9
14	2.1	50	11.5
12	3.3	60	13.5
10	5.3	80	18.0
8	8.4	90	20.5
6	13.3	94	21
4	21.2	133	30
3	26.7	156	35
2	33.6	186	42
1	42.4	236	53
1/0	53.5	285	64
2/0	67.4	285	64
3/0	85.0	351	79
4/0	107	427	96
250	127	427	96
300	152	441	99
350	177	503	113
400	203	503	113
500	253	578	130
600	304	578	130
700	355	645	145
750	380	690	155
800	405	690	155
900	456	702	158
1000	507	778	175
1250	633	965	217
1500	760	1174	264
1750	887	1347	303
2000	1010	1521	342

**UL COPYRIGHTED MATERIAL –
NOT AUTHORIZED FOR FURTHER REPRODUCTION OR
DISTRIBUTION WITHOUT PERMISSION FROM UL**

Table 10
Cord or cable secureness test values
 (See Clauses 5.12.1 and 5.12.4)

Device rating, amperes	Force		Torque		Maximum displacement
	lbf	N	ft-lb	N•m	mm
15	30	133	0.3	0.41	2.4
16 – 20	30	133	0.4	0.54	2.4
21 – 35	75	333	0.5	0.68	2.4
36 – 70	150	667	1.0	1.4	2.4
71 – 125	150	667	2.0	2.7	2.4
126 – 200	150	667	4.0	5.4	2.4
201 – 400	300	1334	8.0	10.8	4.8
401 – 800	600	2668	12.0	16.3	4.8

Table 11
Minimum withdrawal force
 (See Clause 5.15.1)

Device rating, amperes	Minimum withdrawal force ^a	
	N	lb
15	18	4
16 – 20	22	5
21 – 35	27	6
36 – 70	67	15
71 – 125	89	20
126 – 800	111	25

^a The minimum withdrawal force includes the weight of the test plug. If the weight of the mating plug exceeds the specified withdrawal force, the device shall retain the test plug.

Table 12
Short-time test currents
 (See Clause 5.16.1)

Device rating, amperes	Minimum size equipment grounding (bonding) conductor (copper)		Time, seconds	Test current, amperes
	AWG	mm ²		
0 – 15	14	2.1	4	300
16 – 20	12	3.3	4	470
21 – 60	10	5.3	4	750
61 – 100	8	8.4	4	1180
101 – 200	6	13.3	6	1530
201 – 300	4	21.2	6	2450
301 – 400	3	26.7	6	3100
401 – 500	2	33.6	6	3900
501 – 600	1	42.4	6	4900
601 – 800	1/0	53.5	9	5050

**UL COPYRIGHTED MATERIAL –
 NOT AUTHORIZED FOR FURTHER REPRODUCTION OR
 DISTRIBUTION WITHOUT PERMISSION FROM UL**

Table 13
Short circuit test values
 (See Clauses 5.17.1.1, 5.17.2.13 and 5.17.2.15)
 (In the United States only)

Device rating, horsepower (kw)		Test current amperes ^a	Power factor ^c
1.5 – 50	(1.1 – 37.3)	5,000 ^b	0.70 – 0.80
51 – 200	(38 – 149)	10,000	0.70 – 0.80
201 – 400	(150 – 298)	18,000	0.25 – 0.30
401 – 600	(299 – 447)	30,000	0.15 or less
601 – 643	(448 – 480)	42,000	0.15 or less

^a Symmetrical rms amperes.
^b 10,000 amperes at manufacturer's option.
^c Lower power factors may be used.

Table 14
Ratings of fuses used for test
 (See Clauses 5.17.2.1(b), 5.17.2.5, and 7.1.13.3)
 (In the United States only)

Type of fuse ^a	Current, amperes	Maximum percent of rated motor full-load current ^b	Fuse size marking required
Non time-delay	0 – 600	400 ^{c,d}	No
Non time-delay	0 – 600	< 400 but ≥ 300 ^e	Yes
Non time-delay	0 – 600	< 300 but > 225 ^f	Yes
Time-delay	0 – 600	≤ 225 ^g	Yes
Non time-delay	601 – 6000	300 ^h	No
Non time-delay	601 – 6000	< 300 ⁱ	Yes

^a Tests with 225 percent full load ampere time delay fuses are not considered representatives of tests with 400 percent full load ampere non time-delay fuses.
^b These values are approximate and shall be used when the manufacturer does not specify fuse sizes but refers to a maximum percent level, such as "Fuse not to exceed 300 percent of motor full load amps".
^c If the calculated value of the fuse is between two standard ratings as specified in Clause 5.17.2.4, a fuse of the nearest standard rating but not more than four times the full-load motor-current rating shall be used. If the calculated value of the fuse is less than 1 ampere, a fuse rated 1 ampere shall be used, and no marking of fuse size shall be required on the product.
^d Tests with 400 percent non time-delay fuses cover use with 225 percent time delay fuses.
^e Tests with non-time delay fuses rated less than 400 percent, but equal to or greater than 300 percent, cover use with 175 percent time-delay fuses.
^f Tests with less than 300 percent non time-delay fuses require additional testing with 225 percent (or as marked) time-delay fuses.
^g The product is marked to indicate the level of protection and that the branch-circuit protective device may need to be of the time-delay type.
^h If the calculated value of the fuse is between two standard ratings as specified in Clause 5.17.2.4, a fuse of the nearest standard rating but not more than three times the full-load motor-current rating shall be used.
ⁱ The protective device may be a non time-delay fuse smaller than the size specified in note h if the product is marked to indicate this limit of protection.

Table 15
Short-circuit power factor
(See Clause 5.17.3.3.5)
(In the United States only)

Short-circuit power factor, percent	Ratio M_M	Ratio M_A	Short-circuit power factor, percent	Ratio M_M	Ratio M_A
0	1.732	1.394	30	1.130	1.066
1	1.696	1.374	31	1.121	1.062
2	1.665	1.355	32	1.113	1.057
3	1.630	1.336	33	1.105	1.053
4	1.598	1.318	34	1.098	1.049
5	1.568	1.301	35	1.091	1.046
6	1.540	1.285	36	1.084	1.043
7	1.511	1.270	37	1.078	1.039
8	1.485	1.256	38	1.073	1.036
9	1.460	1.241	39	1.068	1.033
10	1.436	1.229	40	1.062	1.031
11	1.413	1.216	41	1.057	1.028
12	1.391	1.204	42	1.053	1.026
13	1.372	1.193	43	1.049	1.024
14	1.350	1.182	44	1.045	1.022
15	1.330	1.171	45	1.041	1.020
16	1.312	1.161	46	1.038	1.019
17	1.294	1.152	47	1.034	1.017
18	1.277	1.143	48	1.031	1.016
19	1.262	1.135	49	1.029	1.014
20	1.247	1.127	50	1.026	1.013
21	1.232	1.119	55	1.015	1.008
22	1.218	1.112	60	1.009	1.004
23	1.205	1.105	65	1.004	1.002
24	1.192	1.099	70	1.002	1.001
25	1.181	1.093	75	1.0008	1.0004
26	1.170	1.087	80	1.0002	1.00005
27	1.159	1.081	85	1.00004	1.00002
28	1.149	1.075	100	1.00000	1.00000
29	1.139	1.070			

*UL COPYRIGHTED MATERIAL –
NOT AUTHORIZED FOR FURTHER REPRODUCTION OR
DISTRIBUTION WITHOUT PERMISSION FROM UL*

Table 16
Total number of operating cycles
(See Clause 5.20.7)

Device rating, amperes	Cycles with load at rated current and voltage	No-load cycles	Sequence
15 – 20	5000	0	–
21 – 63	1000	1000	Alternately
64 – 250	250	250	Alternately
251 – 800	0	250	–

Table 17
Standard electromagnet loads^c
(See Clauses 5.24.1 and 5.24.2)

Test potential in volts	Standard duty (Codes B and P)		Heavy duty (Codes A and N)	
	Normal current	Current inrush	Normal current	Current inrush
120 ac ^a	3.0	30	6.0	60
240 ac ^a	1.5	15	3.0	30
480 ac ^a	0.75	7.5	1.5	15
600 ac ^a	0.6	6	1.2	12
125 dc ^b	1.1	–	2.2	–
250 dc ^b	0.55	–	1.1	–
600 dc ^b	0.2	–	0.4	–

^a Power factor 0.35 or lower.

^b Inductive loads, as specified in UL 508 or CSA C22.2 No. 14.

^c For other values, see UL 508 or CSA C22.2 No. 14.

Table 18
Minimum lettering heights
(See Clause 7.1.5.1)

Device rating amperes	Minimum height of lettering	
	mm	inch
Less than 40	1.5	1/16
40 or more and under 150	3.0	1/8
150 or more and under 400	6.0	1/4
400 or more	12.0	1/2

Table 19
Identification of wiring terminals
(See Clause 7.2.2.1)

Identification by:	Grounded terminal	Grounding terminal	All other terminals
Wire-binding screw	White metal or plating on screw head	Hexagonal, green-colored nut ^b or slotted screw head ^b	Other than white, gray, or green circular screw head
Pressure wire terminal-visible	White metal or plating on connector	Green-colored connector or appendage ^b	Other than white, gray, or green colored terminal
Pressure wire terminal-concealed	Distinct white-colored area adjacent to wire entrance hole, or the word "white", or the letter "W" distinctively marked adjacent to wire entrance hole ^c	Distinct green-colored area adjacent to wire entrance hole, or the word "green" or "ground", the letters "G" or "GR", or the grounding symbol ^d distinctively marked adjacent to wire entrance hole ^c	Other than white, gray, or green area adjacent to wire entrance hole
Set screw	Distinct white-colored area adjacent to wire entrance hole, the word "white", or the letter "W" distinctively marked adjacent to wire entrance hole ^c	Distinct green-colored area adjacent to wire entrance hole, or the word "green" or "ground", the letters "G" or "GR", or the grounding symbol ^d distinctively marked adjacent to wire entrance hole ^c	Other than white, gray, or green area adjacent to wire entrance hole
Terminal plate ^a	White metal or plating	–	Other than white, gray, or green metal or plating
Insulating enclosure or terminal	The word "white" or the letter "W", marked on or directly adjacent to terminal ^c , or white metal or plating on terminal	The word "green", the word "ground", or the letters "G" or "GR" ^c marked on or directly adjacent to terminal, or green colored terminal, or the grounding symbol ^d	–
			Other than white, gray, or green-colored terminal
^a Only if all line-terminal binding screws are of the same color. ^b Not readily removable. See 7.2.2.2. ^c In letters at least 1/16 inch (1.6 mm) high. ^d The grounding symbol shown in Figure 4 is permitted.			

Table 20
Identification of leads
(See Clause 7.2.2.1)

Identification by:	Grounded conductor	Grounding (or bonding) conductor	All other conductors
Color of braid ^b	Solid white or gray (without tracer)	Not applicable	White or gray with tracer in braid or Solid color other than white, gray, or green ^a (without tracer)
	Color other than white, gray or green, with tracer in braid	Not applicable	Solid color other than white, gray, or green ^a (without tracer)
Color of insulation ^b	Solid white or gray; stripe, white or gray, on contrasting color other than green ^a	Green with or without one or more yellow stripes	Solid color other than white, gray, or green ^a
Color of separator ^b	Solid white or gray	Not applicable	Solid color other than white, gray, or green ^a
Conductor tinning ^c	Tin or other acceptable metal on all strands of the conductor	Not applicable	No tin or other white metal on the strands of the conductor

^a A green wire, with or without one or more yellow stripes, shall be used only as an equipment grounding (bonding) conductor.

^b If color of braid, insulation, or separator is used for identification, all conductors shall be either tinned or not tinned.

^c If conductor tinning is used for identification, all braids and/or insulation shall have the same color and shape.

Figure 1
Articulate probe with web stop

[See Clauses 4.7.4, 4.8.1, 4.8.3, 4.8.7, 5.6.1(a), 5.13.5(a), and 5.14.4(a)]

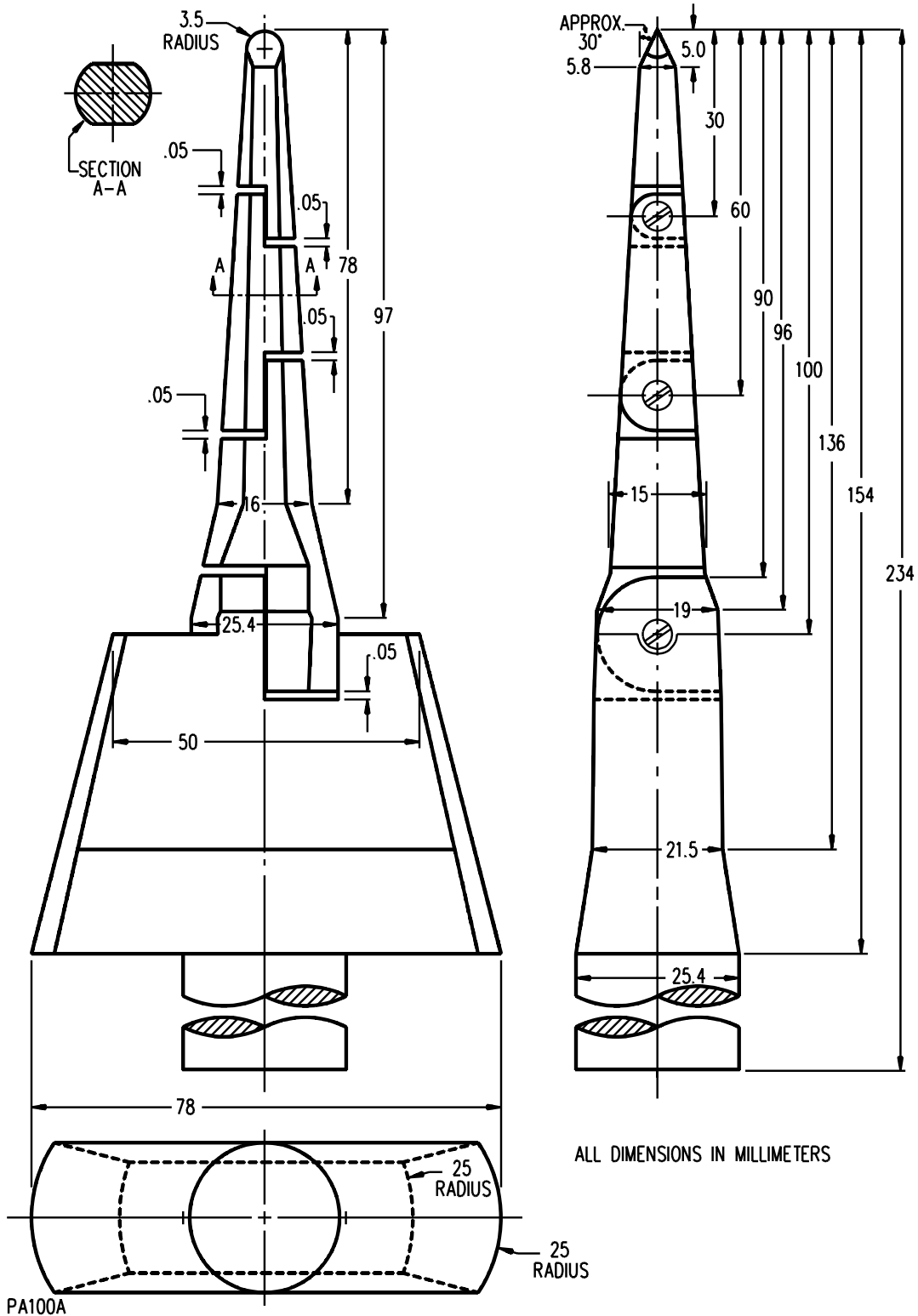

UL COPYRIGHTED MATERIAL –
NOT AUTHORIZED FOR FURTHER REPRODUCTION OR
DISTRIBUTION WITHOUT PERMISSION FROM UL

Figure 2
Impact test equipment
(See Clause 5.13.2)

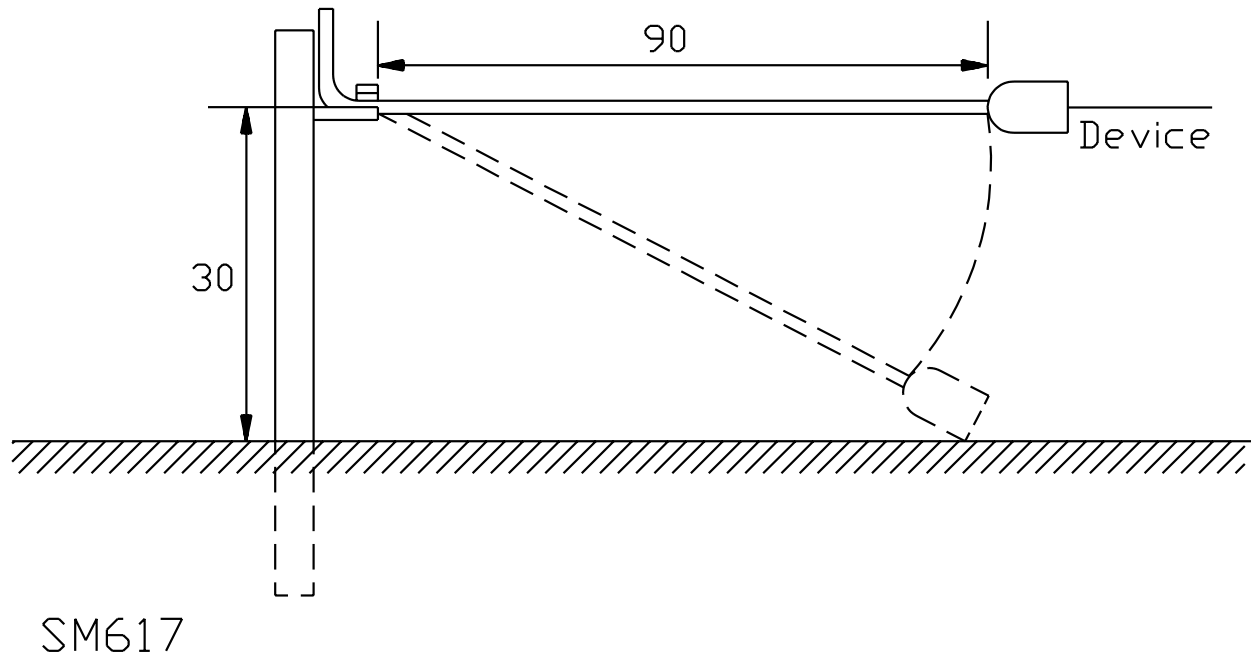

Note: All dimensions given are in mm (inches).

**UL COPYRIGHTED MATERIAL –
NOT AUTHORIZED FOR FURTHER REPRODUCTION OR
DISTRIBUTION WITHOUT PERMISSION FROM UL**

Figure 3
Determination of current and power factor
 for circuits of 10,000 amperes and less
 (See Clause 5.17.3.2.1)

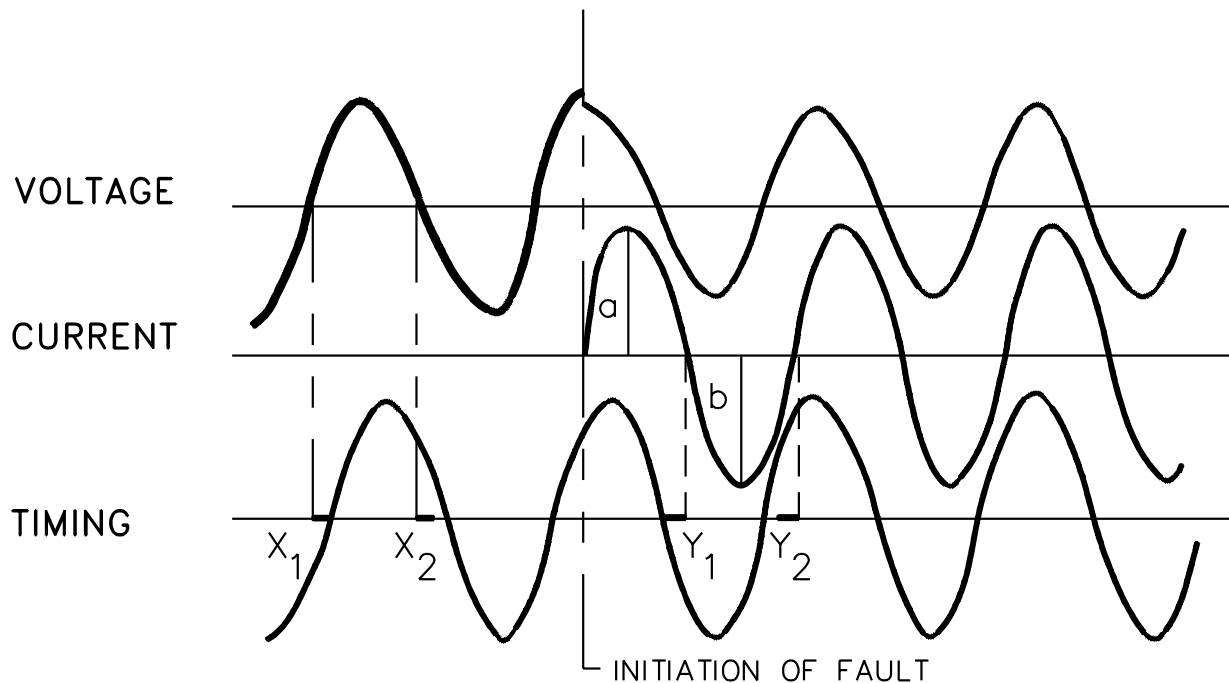

$$\text{Current} = \frac{a+b}{2} \text{ rms calibration of instrument element}$$

$$\text{Power Factor} = \frac{\text{Cos}[(Y_1+X_1) \times 180^\circ]}{2} + \frac{\text{Cos}[(Y_2+X_2) \times 180^\circ]}{2}$$

Where X and Y values are fractions of the 1/2-cycle distance in which they occur.

SB0740B

Figure 4
Grounding Symbol
(See Table 19)

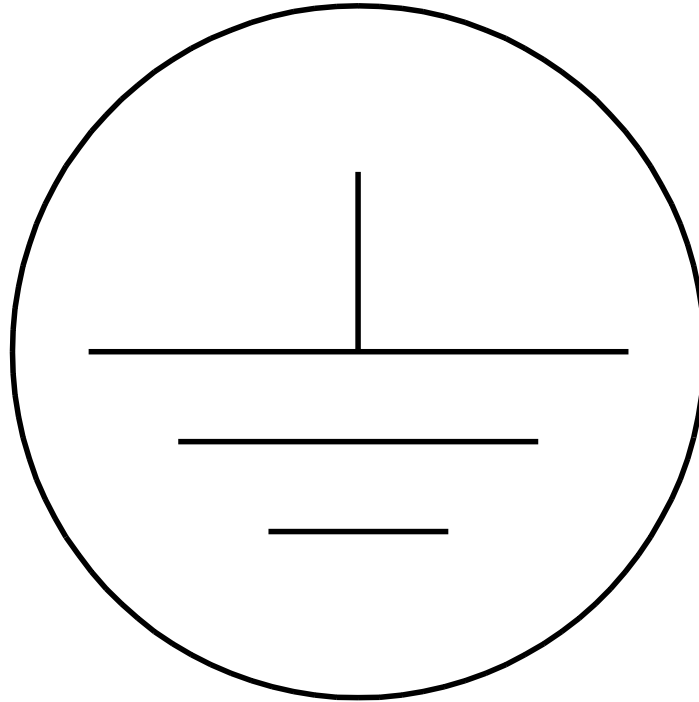

GND1

ANNEX A

Component Standards

The CSA and UL Standards listed below are used for evaluation of components and features of products covered by this standard. Components need only comply with the applicable component standard acceptable in the country where the product is to be used. These standards shall be considered to refer to the latest edition and all amendments published to that edition.

CSA Standards

C22.2 No. 0.15,
Adhesive Labels

CAN/CSA-C22.2 No. 0.17,
Evaluation of Properties of Polymeric Materials

C22.2 No. 14,
Industrial Control Equipment

C22.2 No. 39,
Fuseholder Assemblies

C22.2 No. 111,
General-Use Snap Switches

CAN/CSA-C22.2 No. 94,
Special Purpose Enclosures

C22.2 No. 248-1,
Low-Voltage Fuses – Part 1: General Requirements

C22.2 No. 248-5,
Low-Voltage Fuses – Part 5: Class G Fuses

C22.2 No. 248-6,
Low-Voltage Fuses – Part 6: Class H Non-Renewable Fuses

C22.2 No. 248-7,
Low-Voltage Fuses – Part 7: Class H Renewable Fuses

C22.2 No. 248-8,
Low-Voltage Fuses – Part 8: Class J Fuses

C22.2 No. 248-9,
Low-Voltage Fuses – Part 9: Class K Fuses

C22.2 No. 248-10,
Low-Voltage Fuses – Part 10: Class L Fuses

C22.2 No. 248-12,
Low-Voltage Fuses – Part 12: Class R Fuses

**UL COPYRIGHTED MATERIAL –
NOT AUTHORIZED FOR FURTHER REPRODUCTION OR
DISTRIBUTION WITHOUT PERMISSION FROM UL**

C22.2 No. 248-15,
Low-Voltage Fuses – Part 15: Class T Fuses

UL Standards

Standards for Safety –

UL 489
Circuit Breakers, Molded-Case Switches, and Circuit-Breaker Enclosures, Molded-Case

UL 514B
Conduit, Tubing and Cable Fittings

UL 1581
Electrical Wires, Cables, and Flexible Cords, Reference Standard for

UL 50
Enclosures for Electrical Equipment

UL 62
Flexible Cords and Cables

UL 512
Fuseholders

UL 248-1
Fuses, Low-Voltage – Part 1: General Requirements

UL 248-5
Fuses, Low-Voltage – Part 5: Class G Fuses

UL 248-6
Fuses, Low-Voltage – Part 6: Class H Non-Renewable Fuses

UL 248-7
Fuses, Low-Voltage – Part 7: Class H Renewable Fuses

UL 248-8
Fuses, Low-Voltage – Part 8: Class J Fuses

UL 248-9
Fuses, Low-Voltage – Part 9: Class K Fuses

UL 248-10
Fuses, Low-Voltage – Part 10: Class L Fuses

UL 248-12
Fuses, Low-Voltage – Part 12: Class R Fuses

UL 248-15
Fuses, Low-Voltage – Part 15: Class T Fuses

**UL COPYRIGHTED MATERIAL –
NOT AUTHORIZED FOR FURTHER REPRODUCTION OR
DISTRIBUTION WITHOUT PERMISSION FROM UL**

UL 157

Gaskets and seals

UL 467

Grounding and Bonding Equipment

UL 508

Industrial Control Equipment

UL 840

Insulation Coordination Including Clearances and Creepage Distances for Electrical Equipment

UL 969

Marking and Labeling Systems

UL 514A

Outlet Boxes, Metallic

UL 514C

Outlet Boxes – Nonmetallic, Flush-Device Boxes, and Covers

UL 94

Plastic Materials for Parts in Devices and Appliances, Tests for Flammability of

UL 746D

Polymeric Materials – Fabricated Parts

UL 746B

Polymeric Materials – Long Term Property Evaluations

UL 746A

Polymeric Materials – Short Term Property Evaluations

UL 746C

Polymeric Materials – Use in Electrical Equipment Evaluations

UL 98

Switches, Enclosed and Dead-Front

UL 20

Switches, General-Use, Snap

UL 510

Tape, Polyvinyl Chloride, Polyethylene, and Rubber Insulating

UL 1059

Terminal Blocks

UL 310

Terminals, Electrical Quick-Connect

UL 224

Tubing, Extruded Insulating

**UL COPYRIGHTED MATERIAL –
NOT AUTHORIZED FOR FURTHER REPRODUCTION OR
DISTRIBUTION WITHOUT PERMISSION FROM UL**

UL 486A-486B
Wire Connectors

UL 486C
Wire Connectors, Splicing

UL 486E
Wiring Terminals for Use with Aluminum and/or Copper Conductors, Equipment

***UL COPYRIGHTED MATERIAL –
NOT AUTHORIZED FOR FURTHER REPRODUCTION OR
DISTRIBUTION WITHOUT PERMISSION FROM UL***

ANNEX B

Mandatory English and French Markings for Canada

Advisory Note: *In Canada, there are two official languages, therefore, it is necessary to have CAUTION, WARNING, and DANGER instructions in both English and French. Annex B lists acceptable French translations of the instructions specified in this standard. When a product is not intended for use in Canada, cautionary instructions are not prohibited from being provided in English only.*

Clause 7.1.4.1:

“CAUTION – Risk of Electric Shock. Do Not Disconnect Under Load”.

“ATTENTION – Risque de chocs électriques. Ne pas débrancher sous tension.”

Clause 7.1.5.1

“CAUTION”.

“ATTENTION”.

Clause 7.1.6

“AC”.

“C.A.”.

“AC Only”.

“C.A. seulement”.

“60 Hertz”.

“60 hertz”.

“Wye”.

“étoile”.

Clause 7.1.7.1

“enclosure grounded”.

“boîtier mis à la terre”.

Clause 7.1.9.1

“Use only with a ___ volt fuse”.

“Utiliser seulement avec un fusible de ___ volts”.

Clause 7.1.10.1

**UL COPYRIGHTED MATERIAL –
NOT AUTHORIZED FOR FURTHER REPRODUCTION OR
DISTRIBUTION WITHOUT PERMISSION FROM UL**

“Turn and pull”.

“Tourner et tirer”.

Clause 7.1.13.2

“Maximum Overcurrent Protection Shall Not Exceed the Ampere Rating of This Device”.

“La protection maximale contre les surintensités ne doit pas dépasser le courant nominal de ce dispositif”.

“Maximum Overcurrent Protection ___ Amperes”.

“Protection maximale contre les surintensités: ___ ampères”.

“Protect With Maximum ___ Ampere Fuses”.

“Protéger avec des fusibles d’au plus ___ ampères”.

“Protect With Maximum ___ Ampere Time Delay Fuses”.

“Protéger avec des fusibles temporisés d’au plus ___ ampères”.

Clause 7.1.13.3

“Suitable For Use On A Circuit Capable Of Delivering Not More Than ___ rms Symmetrical Amperes, ___ Volts Maximum”.

“Autorisé pour des circuits d’au plus ___ ampères symétriques efficaces, maximum ___ volts”.

“When Protected by ___ Class Fuses”.

“Avec protection par des fusibles de classe ___”.

“When Protected by Time Delay ___ Class Fuses”.

“Avec protection par des fusibles temporisés de classe ___”.

“When Protected By A Circuit Breaker Having An Interrupting Rating Not Less Than ___ rms Symmetrical Amperes, ___ Volts Maximum”.

“Avec protection par un disjoncteur ayant un pouvoir de coupure nominal d’au moins ___ ampères symétriques efficaces, maximum ___ volts”.

Clause 7.1.13.4

“Suitable for Use Only on Motor Branch Circuits”.

“Autorisé uniquement pour les circuits de dérivation de moteur”.

“Maximum Overcurrent Protection ___ Amperes”.

“Protection maximale contre les surintensités: ___ ampères”.

“Protect With Maximum ___ Ampere Fuses”.

“Protéger avec des fusibles d’au plus ___ ampères”.

“Protect With Maximum ___ Ampere Time Delay Fuses”.

“Protéger avec des fusibles temporisés d’au plus ___ ampères”.

Clause 7.1.14.3

“Watertight”.

“étanche à l’eau”.

“Corrosion Resistant”.

“résistant à la corrosion”.

Clause 7.1.14.5

“To maintain enclosure rating, use only with a device with identical marking”.

“Afin de maintenir le degré de protection du boîtier, utiliser seulement avec un dispositif ayant aussi le marquage ”.

Clause 7.1.15.1

“Watertight”.

“étanche à l’eau”.

No Text on This Page

***UL COPYRIGHTED MATERIAL –
NOT AUTHORIZED FOR FURTHER REPRODUCTION OR
DISTRIBUTION WITHOUT PERMISSION FROM UL***